

Appendix C-3

Protection Requirements & Guidelines Small Generator Connection

A. Introduction

The protection requirements identified in this document apply to customers with small generators which are less than 5 MW capacity and less than 50% of substation light load demand, but greater than 100 kW. It may be an Independent Power Producer (IPP), and all other customer facilities that are capable of feeding into Okanogan PUD's 13.2 kV electrical distribution system.

This document will specify the protection requirements and guidelines applicable to Generation – Distribution Connection Projects.

The Okanogan PUD System, the Douglas PUD System, and the Bonneville System interconnect at numerous locations. Due to the proximity of the Okanogan PUD-Bonneville and/or Okanogan PUD-Douglas PUD points of interconnection, Project protection schemes may require coordination with Douglas PUD/Bonneville and Okanogan PUD protection schemes. In some cases, Okanogan PUD, Douglas PUD, and/or Bonneville protection requirements will apply to the Project protection scheme. As a result, references to the "Okanogan PUD System" contained in this document may, to varying degrees, include the Bonneville System and/or the Douglas System as well. Okanogan PUD will work with the Project Sponsor, Douglas PUD and/or Bonneville to resolve any discrepancies arising from the use of multiple procedures and technical requirements applicable to a given Project.

The protective relay scheme modifications required on the Okanogan PUD System as well as the recommendations for the relay scheme to be installed at the generating facility are described in this document and are intended to achieve the following objectives:

1. Ensure safety of the general public, Okanogan PUD personnel, and Project personnel.
2. Minimize damage to the property of the general public, Okanogan PUD, and Okanogan PUD customers.
3. Maintain dynamic stability.
4. Minimize system voltage disturbances.
5. Minimize adverse operating conditions on the Okanogan PUD System and to Okanogan PUD's customers.
6. Permit the Project Sponsor to operate the Project in parallel with the Okanogan PUD System in a safe and efficient manner.

To achieve these objectives, certain protective equipment (relays, circuit breakers, etc.) must be installed. These devices ensure that faults or other abnormalities initiate prompt and appropriate disconnection of the Project from the Okanogan PUD System. Protective equipment requirements depend on a number of factors. Significant issues that could affect these requirements include:

- The configuration of the Project. See the example in Figure 1 of this document.
- The connection point to the Okanogan PUD System.
- The level of existing service and protection to adjacent facilities (including those of other Okanogan PUD customers and potentially those of other utilities, particularly Bonneville and/or Douglas PUD).

In addition, certain modifications and/or additions to the Okanogan PUD System including protection equipment will be required at the Project Connection Point. Each individual generation connection will require a protection system consistent with these technical requirements. During the design review process, Okanogan PUD can provide comments or suggestions on the protection, operation, or control of the Project without assuming the legal responsibility for the accuracy of such comments. The Project Sponsor is encouraged to seek expert professional advice from licensed consultants for critical issues and decisions involving safety or protective relaying systems. Okanogan PUD will provide necessary system data on request, so that the protection, operation and control of the Project can be coordinated with the Okanogan PUD System for maximum mutual benefit. Okanogan PUD shall review the Project's final protective relay selection list to identify any modifications and/or additions required to protect the Okanogan PUD System.

Okanogan PUD will work with Project Sponsors to achieve an installation that meets mutual requirements.

Since the protective relaying systems are essential for safe operation of the Western Interconnection, any related Project design, drawings, construction, operation, maintenance, and record keeping are subject to the requirements outlined in this document.

Okanogan PUD cannot assume any responsibility for protection of the Project Sponsor's equipment. Project Sponsors are solely responsible for protecting their equipment in such a manner that faults, imbalances, or other disturbances on the Okanogan PUD System do not cause damage to Project Facilities. The Project Sponsor is also expected to provide proper protective systems to ensure that the Project Sponsor's equipment does not adversely impact the Okanogan PUD System. The Project Sponsor shall follow the IEEE guide for Utility-Consumer interconnections (latest edition of IEEE C37.95) and IEEE guide for AC generator protection (latest edition of IEEE C37.102).

This document specifies certain requirements and obligations for connection with the Okanogan PUD System and compliance with NERC Reliability Standards. It does not address detailed issues pertaining to the feasibility of the Project or whether it can operate in a stable mode and co-exist with the electrical system at the proposed location.

A1. Protection Requirements – Ownership & Maintenance:

Additional protective relays recommended for mitigating any instability from occurring will be considered for implementation prior to the approval of a Project connected to the Okanogan PUD System. Procurement, installation, relay settings, testing, ownership and maintenance of all protection relays and transfer trip equipment connected to Okanogan PUD's System shall be at the Project's expense. After the installation and commissioning of the Project, ownership of the distribution line relaying and associated

communication system equipment will be transferred to Okanogan PUD for operation and maintenance.

Okanogan PUD or its designee will perform equipment maintenance on a regular schedule and provide a detailed documentation of test results, inspection reports, and maintenance records. This work is to include, but not be limited to the following:

- Functional testing of all trip circuits
- Functional testing of circuit breaker(s)/interrupter(s)
- Calibration testing of the settings in all protective relays and communication device settings
- Inspection and maintenance of DC power sources
- Inspection and maintenance of circuit breaker(s)/interrupter(s)

B. Protection Criteria and Design Considerations

The protection system must be designed such that the Project's generating equipment is automatically isolated for the following situations:

- Internal faults within the Project.
- External faults within the power system (as necessary).
- Conditions that indicate abnormal operation, including islanding of the Project.

General Protection Practices as Applied to the Okanogan PUD System

The information below is provided to identify general protection practices as applied to Okanogan PUD's distribution lines and the connections made to it. The protection schemes necessary to integrate the Project must be consistent with these practices and the equipment used to implement them.

B1. All Voltages

1. Distribution system protection requirements and modifications for both new and existing line configurations will be reviewed and determined by Okanogan PUD for each proposed new generation connection on a case-by-case basis.
2. A generator will be allowed to connect to an existing Okanogan PUD distribution facility only if the Project protection scheme can be coordinated with existing Okanogan PUD protective devices, without compromising reliability, system stability, and quality of service to Okanogan PUD's existing customers.
3. Relays, breakers, etc. are required at the Project Connection Point or the connecting substation to isolate the Project's equipment from the Okanogan PUD System during faults or other system abnormalities.
4. The Project shall be synchronized to the Okanogan PUD System. An automatic synchronizing function (e.g. sync check relay) must supervise all closures of the breaker connecting the generator to Okanogan PUD System.
5. Redundant relay and communications are required

6. Dual batteries are NOT required but each set of relays (primary and back-up) may need to have its own separately protected DC branch circuit using either fuses or circuit breakers rated for that application.
7. Redundant relays shall not be connected to a common current transformer winding.
8. A dedicated generator breaker is required at the Project Sponsor's generation site.
9. Any breaker dedicated for the sole purpose of isolating the generator from the power system shall open all three phases and shall not reclose automatically.
10. The Project is not allowed to energize a de-energized line in the Okanogan PUD System without approval of the Okanogan PUD Engineering Department.
11. Breaker reclose supervision (automatic and manual including SCADA) will be required at the substation and/or electrically 'adjacent' Okanogan PUD stations; e.g., hot bus/dead line check, synchronization check, etc.

B2. 13.2 kV

1. Independent sets of line protection relays shall be installed at each line terminal to trip the line terminal breakers.
2. A transfer trip communication scheme will be required on these distribution lines and must be compatible with existing Okanogan PUD equipment. A common communication media must be approved by Okanogan PUD for both relay sets.
3. Total fault-clearing times, with or without a transfer trip scheme, must be provided for Okanogan PUD review and approval. Breaker operating times, relay models, and relay settings must be identified specifically.
4. Relays shall provide backup protection for loss of the communication channel.
5. Automatic reclosing is not allowed.

C. Implications for Generation - Distribution Connection Projects Connected to an Existing Distribution Substation

Generation – Project's may integrate into the Okanogan PUD System through a power transformer that is designed only to serve loads; e.g., connection at the 13.2 kV side of a 115 kV /13.2 kV delta / wye-grounded transformer.

Some existing facilities have fuse protection only on the High Voltage side of the power transformer. Other installations are equipped with a circuit switcher or a circuit breaker with protective relays to isolate the distribution facilities from the High Voltage system for faults within the transformer and act as backup to the low voltage protective relays. The existing designs used at these installations assumed there would not be a generating source on the low-voltage side of the distribution substation transformer that could back-feed a fault on the High Voltage system. For those facilities that presently have fuse protection on the High Voltage side of the substation transformer, a circuit breaker or a circuit switcher with an adequate number of protection class CT's will be required to connect the Project's generation step-up (GSU) transformer to one of the feeders.

Responsible and thorough protective relaying strategies are necessary when generation is connected into these sites. Some factors to consider are:

- 'Neutral shift' can be attributed to connection into stations with a primary (High Voltage) side delta, secondary (low-voltage) side Wye-grounded (D-YG) transformer.
- Ferroresonance is cause of concern, regardless of transformer connection.
- Equipment damage, relay performance, and saturation of measuring devices.

In addition to relays installed at the connecting substation, primary and/or backup relays used for detection of faults in the power system may be required at the Project. In the absence of a connecting substation, primary and/or backup relays used for detection of faults in the power system will be required at the Project. Usually, changes to existing protection and reclosing schemes are not limited to those at the connecting substation.

D. Protection Measures and Protective Relays

The protective relays for the generation connection shall consist of a complete package of devices. Each device is intended to perform specific function(s) tailored to the protection of the Project and the interconnected system. The Project relays shall be specified with the correct ratings and ranges to ensure that proper settings are possible. The relaying package is to include a suitable enclosure that is environmentally controlled so that the relays will remain within their published operating characteristics.

Protection systems must be capable of performing their intended function during fault conditions. This includes the generator contribution to the fault and neutral shift of the unfaulted phases. The duration of this contribution and neutral shift varies with generator size, type, and excitation. The magnitude of fault depends on the fault type, system configuration, and fault location. The discussion below identifies the conditions under which relay schemes must operate. Notably, the issues are:

- Infeed detection to phase and ground faults,
- Islanding,
- Synchronizing and reclosing,
- Unique problems related to system configuration.

D1. Phase Fault Detection

Phase overcurrent (type 50/51) and neutral overcurrent (type 50/51-N) relays are provided to detect abnormally high currents. These non-directional relays are used to detect faults on the feeder line and serve to back up generator overcurrent relays. Line differential relays will be a necessary consideration for some generators when coordination with other relays is not possible.

Infeed detection of faults within the Okanogan PUD System usually requires directional current-sensing relays to remove the Project's contribution to the fault. Zone-distance relays (type 21) can serve this need. However, some generation projects (generally 'small-capacity') may not contribute sufficient infeed to power system phase faults to make the distance relay's infeed detection feasible. In these cases, relays at the Project need to provide the necessary detection.

D2. Ground Fault Detection

Ground fault detection has varying requirements. The most significant consideration in ability to detect ground faults on the utility power system is the winding configuration of the transformer connecting the Project to Okanogan PUD's distribution system.

The scenarios below assume that the Project is connected to the low-voltage side of this transformer.

D2-1. Transformer Delta Connection on the High Voltage Side

This portion of the document applies only to existing customers connected to Okanogan PUD's 115 kV facilities where generation was not originally considered at the low voltage bus. At these locations the step-down transformer is connected delta/wye-grounded (D-YG): delta on the High Voltage winding and wye-grounded on the low-voltage winding.

In this configuration with generation connected to the low voltage bus (Figure 1), the High Voltage line is left ungrounded when protective relay operation at the remote distribution line terminal(s) isolate the line from the rest of the system. The subsequent generator infeed (voltage effect) will continue to energize the distribution line and, with one phase grounded, can result in significant overvoltages (neutral shift).

In this case, local protective relaying would not be able to detect zero sequence current for ground faults on the distribution system unless a ground source (grounding bank) is present on the High Voltage side of the transformer.

Thus protection must be applied to detect ground faults and trip the generator breaker as rapidly as possible. In the absence of a grounding bank, a preferred detection method for this situation is to use three potential transformers on the distribution side of the transformer connected phase-to-ground. The potential transformers must be capable of measuring voltages up to 1.9 PU without the output collapsing by the operation of a protective device, such as a protective gap. The secondary windings of the potential transformers are connected 'broken-delta' with an overvoltage relay (type 59-Z) connected across the 'open' corner of the delta. The relay measures the sum of the phase-to-neutral voltages. Under normal conditions, this voltage measurement is near zero. However, a ground fault either close to the transformer or with the remote line end(s) open yields a substantial voltage. The relay initiates a trip to eliminate the generator infeed on the faulted line.

Fault detection using a single potential transformer and an over/undervoltage relay is not usually acceptable. Fault impedance, connected loads, and/or additional ground sources on the line can significantly compromise the ability of this scheme to detect the over-or-undervoltage condition. However, when both of the following system conditions exist, a single potential transformer scheme is acceptable because the system voltage should rapidly collapse after the remote end breakers trip:

- 1) The minimum load (MW) in the 'local island' is four or more times the generator rating (MVA) and
- 2) The available system reactive power (capacitive VAR's) is less than 25% of the generator rating.

- 3) Transfer trip from the end(s) of the distribution line is an acceptable alternative. A grounding bank connected to the high side (delta side) of the step-up power transformer along with ground overcurrent relays is another acceptable alternative.

D-3. High-Side Overvoltage Protection

For the scenario described above, with the high side connected in delta and without a grounding transformer, the distribution line is ungrounded. With a generator energizing the circuit and a fault on the distribution line, the voltages on the unfaulted phases can reach 1.7 PU and higher (full neutral shift). This can stress equipment insulation and cause rapid failure of surge arresters. Additional protective relays are required, to detect this overvoltage situation quickly and disconnect the generator from the circuit.

Three single-phase instantaneous overvoltage relays (type 59) are to be installed to detect phase-ground voltage using the three high-side potential transformers. These relays shall be set to trip at 1.5 PU phase-ground voltage and have approximately a one-cycle detection time. Like the ground-fault detection scheme above, transfer trip from the distribution line end(s) is an acceptable alternative to this high-side overvoltage protection.

The 'open delta' protection scheme described above is intended to detect ground faults and assure a local trip of the generator. However, proper coordination of this scheme often requires relaying delays. Such delays may not provide adequate protection for equipment such as high-side arresters. The open delta scheme also cannot protect for the case of overvoltages created when a small generator is isolated in a 'local island' with a relatively large amount of capacitance, such as a long line or a capacitor bank. The simple and inexpensive set of three overvoltage relays described above are intended to protect the arresters and other equipment on the High Voltage side with no intentional delays, regardless of the cause of the overvoltages.

E. Islanding

Islanding describes a condition where the power system splits into isolated load and generation groups, usually when breakers operate for fault clearing or system stability remedial action. Generally, the 'islanded groups' do not have a stable load to generation resource balance. However, it is possible that, under unique situations, generator controls can establish a new equilibrium in an islanded group.

When Okanogan PUD customer loads are being served over the utility's distribution system, where generation is also connected, implications of islanding must be addressed to minimize adverse impacts on these loads. If a generator can be islanded, then additional protection is required to prevent this possibility. Based on protection studies, either a transfer trip scheme will be required or additional protective relays will be needed at the Project to monitor voltage and frequency. These additional relays are applied to protect Okanogan PUD customer loads from damage: over/undervoltage (type 59/27), and over/underfrequency (type 81). These relays are intended to trip the generator for the large voltage and frequency deviations that would tend to occur during a 'local islanding' condition. However, they are also set so the generator does not trip for the less severe deviations that could occur during most major disturbances on the connected power system.

F. Synchronizing

The Project generator(s) shall be synchronized to the Okanogan PUD System. All breaker closing operations must automatically synchronize (e.g. using a sync check relay) the Project generator to the Okanogan PUD System. The point of synchronism depends on the configuration of the Project's Connection Point. The breaker used to synchronize the generator to the power system is usually the dedicated generator breaker.

G. Line Reclosing

If the Project's generator interconnects to an existing line, automatic reclosing schemes at Okanogan PUD's remote line breakers will need to be modified. These schemes will require voltage-supervision logic for time-delayed or instantaneous reclosing. Okanogan PUD reserves the right to change the reclosing time interval based on system requirements. Under certain system condition circumstances, Okanogan PUD will need to temporarily disable automatic reclosing at one or both remote ends. The Project Sponsor/Operator shall be notified well in advance of any changes in the reclosing scheme to allow the Project Sponsor and/or Project Operator to make any necessary adjustments.

Okanogan PUD will implement the following protection circuit modification to ensure that the remote breakers on the existing system will not reclose until the generators are off-line:

- **Voltage Supervision on Reclosing:** A hot bus/dead line or hot bus/hot line voltage supervision check will be required at each of the remote utility breakers before automatic reclosing at either end is attempted. Potential devices on the line-side of the breakers and an undervoltage relay will be necessary at the Okanogan PUD and, in some circumstances, Bonneville and/or Douglas PUD substations to help ensure that Okanogan PUD will only reclose its circuit breakers when the generator is off-line and the line is dead. The voltage sensing devices will be installed on a minimum of one phase and could be required on all three phases.

H. Transfer Trip Requirements

Relay Project shown in Figure 1 are designed to isolate the Project from the Okanogan PUD System at the Connection Point. However, the clearing time speed of these local relay systems and the associated isolating equipment (breakers, etc.) will vary. Integration of generating projects into the Okanogan PUD System requires equal or better performance of their protection systems. In most cases, transfer trip communications are necessary. A transfer trip signal shall be transmitted via Okanogan PUD's fiber optic system, microwave system, or by dedicated fiber. Transfer trip is required when any of the conditions listed below implies the need for it.

1. Transient or steady state studies identify system instability under conditions that require immediate isolation of the Project from the power system or as determined by operational control needs.
2. The total clearing times identify the maximum permissible fault duration times allowed to provide prudent response to fault conditions. Extended fault duration represents an additional safety hazard to personnel and can cause significant damage to power system equipment (lines, transformers). Relay operating times are adjusted to coordinate for faults based on the local configuration, fault currents available, etc. If Okanogan PUD's

protective relay schemes cannot be altered to accommodate the Project to meet the clearing times listed below, high speed tripping will become necessary.

3. If time delayed fault clearing of adjacent lines in the vicinity of Okanogan PUD customers can cause electrical problems (voltage sag) to their manufacturing process, high speed tripping will become necessary. This scenario is a distinct possibility if a Okanogan PUD circuit that connects the Project and other customer loads becomes part of a local island.
4. When remote breaker tripping is required to clear faults on a transformer not terminated by a high side breaker, high-speed tripping will be necessary. Other unique Okanogan PUD circuit configurations will impose the same requirement for high-speed tripping.

I. Disturbance Monitoring

Unique and unanticipated protection problems can result from the altered Okanogan PUD System configuration due to connection with the Project. At Project expense, Okanogan PUD may install electrical monitoring devices to identify possible protection scheme problems and to provide power quality measurements of the new configuration. If monitoring equipment or relay performance reports indicate inadequate protection of the Okanogan PUD System, the Project will be notified in writing of additional protection requirements. The Project Sponsor is required to add or delete protection equipment or circuitry within 20 working days unless approved by Okanogan PUD. Failure to implement the required changes will be deemed to be operating beyond safety or protection standards. Okanogan PUD reserves the right to disconnect the Project until required changes are made and approved. The monitoring devices used to provide this information will include, but not be limited to, oscillographs, digital fault recorders, harmonic analyzers, and high-speed sequence of events recorders. The availability of accessible current and voltage measurement points will determine the number of channels for the device. At Project expense, other monitoring equipment may also be installed to aid in the understanding of electrical phenomena, such as overvoltages, and ferroresonance that could be associated with the connection of these projects. In addition, at Project expense, communication equipment may be used by Okanogan PUD to provide remote access to these monitored quantities. Okanogan PUD also plans to use the analysis of the information acquired by the aforementioned devices to enhance and update future editions of this document.

J. Relay Coordination

A relay coordination study will need to be performed to ensure proper integration and operation of the Project's generator with Okanogan PUD's existing system equipment. The Project Sponsor shall provide all protection settings that will detect faults on the Okanogan PUD System for a coordination study. Any Project settings that will not coordinate or will adversely affect the proper operation of the Okanogan PUD System will be reset within 20 working days or the Project may be disconnected.

Voltage and frequency relays used for protecting a generator and preventing a 'local island' condition from persisting must meet the following requirements to allow proper coordination with the adjacent power system(s). These relays are usually installed at the generation site or at the connecting substation.

The ranges, settings, and delays below for both voltage and frequency relays are understood by Okanogan PUD to be well within the capabilities of small and large modern steam turbines as well as other generators. Okanogan PUD will evaluate a Project Sponsor's proposed alternative

voltage/frequency settings based upon the impact on system performance and reliability. The settings must comply with existing NWPP and/or WECC requirements.

J1. Voltage Relays

Okanogan PUD operates its system within the voltage guidelines defined in the table below. The Project shall have the capability to operate within the full voltage range at the Connection Project Point so as not to restrict the operational range of Okanogan PUD's distribution system.

System Voltage Guidelines

Nominal Voltage (kV)	Absolute Voltage		Voltage Regulation	
	Minimum	Maximum	Normal	Contingency
13.2	95%	105%	5%	7%
115	95%	103%	5%	5%

* On the unregulated 13.2 kV, the maximum allowable contingency drop is based on BPA's operating and planning criteria.

The Okanogan PUD System contains no undervoltage relaying that is part of a WECC approved undervoltage load shedding scheme. However, the Project Sponsor, Okanogan PUD, Bonneville, and/or Douglas PUD should confer on the need for undervoltage load shedding relays as part of the process to determine the protective relay requirements for the Project.

If connection of Project generation is proposed on any Okanogan PUD 115 kV lines, then transfer trip may be required to disconnect the Project from the Okanogan PUD System when these lines are de-energized and separated from the rest of the Okanogan PUD System. This will prevent 'local islanding' of Okanogan PUD customer loads with the Project's generation. See Section 9E.

For connection of Project generation onto lines not involved in Bonneville's or Douglas PUD's undervoltage load shedding scheme, the Project's undervoltage relay shall be set such that the Project's generation remains on line through the load shedding process to provide maximum power system support. During severe system voltage disturbances it is critical that generators do not trip prior to the completion of all automatic undervoltage load shedding.

These requirements also ensure that generators do not disconnect for dynamic (transient) oscillations on the power system that are stable and damped. The oscillatory frequency of the system during a disturbance may range between 0.25 and 1.5 Hertz.

Voltage relays must have a dropout time no greater than 2 cycles. Voltage relays shall be solid state or microprocessor technology. Electro-mechanical relays used for this function are considered unacceptable.

J2. Frequency Relays

Douglas PUD maintains the underfrequency load shedding scheme applicable to the Okanogan PUD System. The objective of this scheme is to use the machine capability to support the power system and prevent unnecessary loss of customer load during disturbances affecting system frequency, and ultimately, to help prevent system collapse. Generating resources must not trip

off before load is shed by frequency relays. Okanogan PUD, Douglas PUD, and the Project Sponsor shall confer on over/underfrequency relay setting points used for automatic load shedding in accordance with WECC/NWPP requirements and criteria. Such criteria may dictate that the Project implement underfrequency stalling tripping.

The Project's underfrequency relay shall be set such that the Project's generation remains on line through the load shedding process to provide maximum power system support. For the purpose of coordinating plant control devices during faults on the Okanogan PUD System, calculated fault clearing times and voltage dips will be provided for individual cases.

Frequency relays must have a dropout time no greater than 2 cycles. Frequency relays shall be solid state or microprocessor technology.

K. Protective Relays

K1. Relays to be Installed for Integration of the Project

This set of relays has been developed in recognition of varied detection requirements. Relay performance under certain fault scenarios is also a consideration in the selection of these relays. The specific relays used must be functionally consistent with, and complementary to, Okanogan PUD's general protection practices identified in Section B of this document.

The relays generally necessary to serve this purpose are:

- | | |
|---|----------------------------|
| a. Phase overcurrent (non-directional) | (type 50/51) |
| b. Neutral overcurrent (non-directional) | (type 50/51-N) |
| c. Zone distance | (type 21/21-N) |
| d. Directional Phase/Neutral overcurrent | (type 67/67-N) |
| e. Ground overcurrent
or ground fault detection scheme | (type 51-G)
(type 59-Z) |
| f. Over/undervoltage | (type 59/27) |
| g. Over/underfrequency | (type 81) |
| h. Instantaneous overvoltage (for ungrounded high-side) | (type 59) |
| i. Reverse power flow relay | (type 32) |
| j. Synchronism check relay | (type 25) |
| k. Remote automatic breaker reclose supervision
(HB/DL, HB/HL with synchronism check) | (type 79-X) |

Except for Item k. above, these relays are usually located in the connecting substation that contains the GSU. Some or all may be located elsewhere if the connection to the Project suggests an equally acceptable or more logical location. All Project Sponsor relays shall be of 'utility grade' quality, subject to review by Okanogan PUD.

Slow clearing or other undesirable operations (e.g., extended overvoltages, ferroresonance, etc.), which can not be resolved by local conventional protection measures, will require the addition of transfer trip using remote relay detection at other substation sites.

Refer to the section on telecommunication as it pertains to control and protection requirements. See Figure 1 for an example of typical integration plans.

K2. Additional Relays

Although not required by Okanogan PUD, the Project Sponsor may note value in additional relays to isolate and protect the generator. Some of the most commonly used relays include:

- | | |
|--------------------------------------|-------------|
| a. Percentage differential | (type 87) |
| b. Phase balance current | (type 46) |
| c. Phase sequence voltage | (type 47) |
| d. Thermal | (type 49) |
| e. Loss of field | (type 40) |
| f. Over-speed device | (type 12) |
| g. Transformer sudden pressure | (type 63) |
| h. Voltage controlled/restrained o/c | (type 51-V) |
| i. Volts per Hertz (overexcitation) | (type 24) |
| j. Neutral overvoltage | (type 59-N) |

L. Fault Analysis

All operations of protective relays within the Project shall be reviewed and documented. This information shall be available to Okanogan PUD on request to assist in analyzing fault operation on the Okanogan PUD system. To facilitate the analysis of system disturbances and the evaluation of system operation, digital fault recorders/analyzers will be required on certain types of complex substations and at all major generating stations connected to the Okanogan PUD system. Fault recording functions in microprocessor relays may provide the detail data needed to perform the analysis.

Attachments:

Figure 1: Example of integrating Project generation into an existing Okanogan PUD distribution substation.

A - 3: Connection Study Request Form

Version History- This document reviewed with rest of Interconnection Documents

Relay Functions Descriptions for Attachment 1

<u>Relay</u>	<u>Intent</u>
21-1, 21-2, 62	Zone distance relays trip feeder breaker 'B' to eliminate the contribution of the generator to multi-phase faults on the tapped distribution line.
59 Z	Ground fault detection scheme used to detect ground faults on the tapped distribution line. (Normally the open delta 3Vo scheme, inverse time characteristic.) Trips of this relay may need to be time coordinated with other relays so that faults beyond the tapped distribution line do not cause unnecessary trips of the generator feeder. Trips breaker 'B'.
59	Detects overvoltages, and ground faults as indicated above. Instantaneous trip upon overvoltage condition of 1.5 per unit on any phase. Initiates trips of feeder breaker 'B' to avoid arrester failure.
50/51, 50/51N (Transformer)	Protects transformer from overcurrent conditions caused by lowside faults, extreme overloads, or unbalances. Phase overcurrent relays are usually set to pickup at approximately twice the transformer thermal rating. These relays are time-coordinated with lowside feeder relaying (backup). The relays trip breakers 'A' and 'B'. Differential relays (87) may be substituted for the 50/51 and 50/51N.
50/51G (Transformer)	Protects transformer from overcurrent conditions caused by lowside ground faults or extreme unbalances. These relays are time-coordinated with lowside feeder relaying (backup). The relays trip breakers 'A' and 'B'.
50/51, 50/51N (Feeder)	Detects overcurrent condition caused by power system contribution to faults on the generator feeder or in the Project. Also, detects generator infeed to faults at or near the connecting substation. These relays trip breaker 'B'. SEL 351-1 with mirror-bit logic
50/51, 50/51N (Project)	Detects overcurrent condition as caused by generator infeed to faults on the feeder line or connecting substation. Trips breaker 'D'. Voltage restrained time overcurrent phase relays, 51-V, may be desirable rather than the 51 for better selectivity of fault currents vs. load currents. SEL 351-1 with mirror-bit logic
27/59	Detects abnormal voltage conditions often caused by islanded operation scenarios. Undervoltage relay can serve as a means of fault detection for instances of weak fault current infeed from generator to faults on the feeder or interconnected system. Protects generator against extended operation at abnormal voltages. Undervoltage relay settings are coordinated with Okanogan PUD undervoltage load shedding (Section J1).
81	Detects abnormal frequency conditions, often caused by islanded operation scenarios. Protects generator against extended operation at abnormal frequencies. Over/ Underfrequency relay settings are coordinated with Okanogan PUD off nominal frequency load shedding (Section J2).
25	Synchronism check supervising function for all closes of generator breaker 'E'.
79 X	Automatic reclose supervision function: Hot Bus/Dead Line (HB/DL), Hot Bus/Hot Line (HB/HL) as required. Synchronism check supervision may also be used at 'L' and/or 'R'. Relays at the remote ends 'L' and 'R' trip respective breakers for faults on the line.

Attachment 1 to Appendix C-3

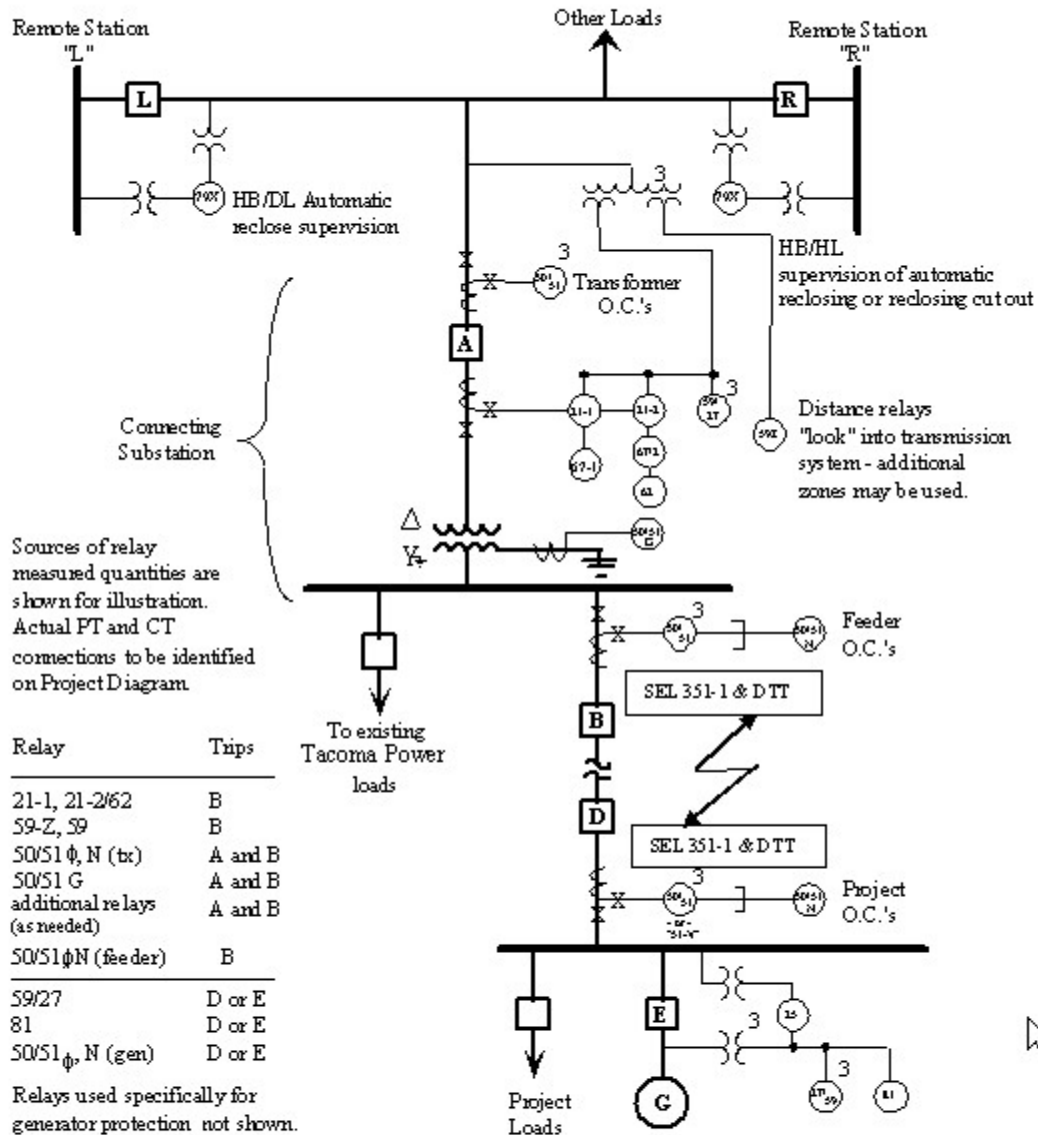

Figure 1 Example of integrating Project's generation into an existing Okanogan PUD Substation Protected by a high-side breaker (switcher) and connected to the high voltage system Through a delta-wye grounded transformer

Attachment A-3 to Appendix C

CONNECTION STUDY REQUEST

WHO SHOULD FILE THIS APPLICATION:

Any customer expressing an interest in interconnecting generation. This application should be completed as soon as possible and returned to the Okanogan PUD Engineering Department, along with the Commission-approved study fee, in order to begin processing the request.

INFORMATION:

This application will be used by Okanogan PUD to perform System Impact Studies to determine the Interface requirements at the customer's Connection Point. The Project Sponsor should attempt to fill in as much of the form as possible. The Project Sponsor will receive a preliminary estimate for the utility interface requirements that may be used in calculating the overall Project requirements.

OWNER/PROJECT SPONSOR INFORMATION

Owner of Project	Project Sponsor
Company	Company
Contact	Contact
Mailing Address:	Mailing Address:
City/State/ 9 Digit Zip Code	City/State/ 9 Digit Zip Code
Phone Number	Phone Number

PROJECT DESIGN/ENGINEERING ARCHITECT (As applicable)

Company			
Mailing Address			
City	County	State	9 Digit Zip Code
Phone Number	Contact		

ELECTRICAL CONTRACTOR (As applicable)

Company			
Mailing Address			
City	County	State	9 Digit Zip Code
Phone Number	Contact		

*Okanogan PUD
(Page 2)*

GENERATOR DATA

Manufacturer (If available)		Model:		
TYPE	Induction	Phases:Single	Three	Frequency (Hz)
Synchronous				
Rated Output:	Kilowatts		Kilovolt-Ampere	
Rated Power Factor	%	Rated Voltage	Volts Rated Amperes:	Amps
Energy Source (Gas, Hydro, Wind, Co-Gen., Geothermal, etc.):				
Plant Load (Auxiliaries)		KW		KVAR
Net Maximum Power to Okanogan PUD		KW		KVAR
Operating Dates and Capacity:		KW		Date
Ultimate Output (Max.)		KW		Date
Estimated Peak and Energy Production (Ultimate Output)				
January		Peak kw		kwh
February		Peak kw		kwh
March		Peak kw		kwh
April		Peak kw		kwh
May		Peak kw		kwh
June		Peak kw		kwh
July		Peak kw		kwh
August		Peak kw		kwh
September		Peak kw		kwh
October		Peak kw		kwh
November		Peak kw		kwh
December		Peak kw		kwh

PROJECT LOCATION

STATE	COUNTY	NEAREST COMMUNITY
-------	--------	-------------------

TOWNSHIP	RANGE	SECTION
----------	-------	---------

STREET ADDRESS

DATE	SIGNATURE
------	-----------

NAME (Please Print or Type)	TITLE
-----------------------------	-------

****ATTACH MAP SHOWING PROJECT BOUNDARIES AND SUBSTATION LOCATION ****

Okanogan PUD
(Page 3)

ELECTRICAL AND SYNCHRONOUS MACHINE INFORMATION

1. Electrical One-Line Diagram of the generation Project that includes proposed protective relaying, breaker and switching arrangements, ground sources (zero sequence), ground resistance (Project to remote earth), and assumed line parameters for and Project tie lines.

2. Shunt capacitors associated with the Project for power factor correction.

kV

kVars

3. Step-up transformer nominal voltage [kV/kV/(kV)], impedance [% @ MVA],

MVA rating(s) [MVA], the electrical configuration (e.g., delta-wye) [.],

and taps and tap range [].

4. Station service load (both kW and KVAR) and the type of load (e.g., 70% motors and 30% heating).

kW

Kva

Load

5. The following machine data:

MVA	Machine base rating on which the data is on (for each unit)
KV	Rated KV
P.F.	Power factor of machine
H	Inertia constant of the machine, MW-sec./MVA
Ra	Armature resistance, pu
Xd	Direct axis unsaturated synchronous reactance, pu
Xq	Quadrature axis unsaturated synchronous reactance, pu
X'd	Direct axis unsaturated transient reactance
X'q	Quadrature axis unsaturated transient reactance
X''d	Direct axis unsaturated subtransient reactance
Xl	Stator leakage reactance
T'do	Direct axis transient open circuit time constant, sec
T'qo	Quadrature axis transient open circuit time constant, sec
T''do	Direct axis subtransient open circuit time constant, sec
T''qo	Quadrature axis subtransient open circuit time constant, sec
P max	Maximum power output of the turbine in MW
S(1.0)	Machine data at 1.0 per unit of rated voltage
S(1.2)	Machine data at 1.2 per unit of rated voltage

6. The type of exciter, block diagram, and parameters in IEEE, PTI or WECC format.

7. The type of power system stabilizer, block diagram and parameters in IEEE, PTI, or WECC format.

8. The type of governor and turbine, block diagram and parameters in IEEE, PTI or WECC format.

9. The turbine frequency versus time operation limits.

To be filled out by the Okanogan PUD Account Executive:

Account Executive

Internal Routing

Phone Number

Copy of connection Study Request and Attachments to:

Engineering
Power Supply