



APPENDIX “B-1”

TECHNICAL CONNECTION REQUIREMENTS

for

GENERATION & INTERCONNECTION FACILITIES

TABLE OF CONTENTS

DEFINITIONS

A. Scope

1. Generation Connection and Operating Agreement
2. Load Following, Regulation, and Reserves
3. Applicable Codes, Standards, Criteria and Regulations
4. Safety, Protection and Reliability
5. Non-Okanogan PUD Responsibilities
6. Cost of Analysis and System Impact Studies
7. Approval and Acceptance

B. Request for Generation and Interconnection Impact Studies

1. Connection Configuration
2. Power Flow, Short Circuit and Stability Analysis
 - a. System Rating and Voltage Screening – power flow analysis
 - b. Transfer Capability – power flow analysis
 - c. Fault Duty – short circuit analysis
 - d. Stability – stability analysis
3. Protection
4. Power Quality and Reliability
 - a. Voltage Unbalance
 - b. Voltage Flicker
 - c. Harmonic Distortion
 - d. Transient Overvoltage
 - e. Temporary Overvoltage
 - f. Temporary Undervoltage
 - g. Insulation Coordination
5. Changes to Project Sponsor-Supplied Information
6. Required Project Sponsor-Supplied Information

C. General Requirements

1. Safety
 - a. Isolation Requirements
 - b. Generation Served by the Project
 - c. Chemical Hazards
2. Connection Point Considerations
 - a. General Configurations and Constraints
 - b. Other Considerations
 1. Equipment
 2. Outage Coordination & Maintenance
 3. Atmospheric & Seismic
3. Substation Grounding
4. Insulation Coordination
 - a. Lightning Surges
 - b. Temporary Overvoltage's
 - c. Normal Operating Voltages
5. Inspection, Verification, Testing, Calibration and Maintenance
 - a. Project Sponsor – Pre-energization, Inspection, Verification and Testing
 - b. Project Sponsor – Equipment Maintenance
6. Station Service
7. Fault Interruption, Synchronization and Black Starts
 - a. Fault Interruption
 - b. Synchronization

TABLE OF CONTENTS (continued)

- c. Blackstart
- 8. Environmental Considerations
 - a. Property Contamination
 - b. Polychlorinated Biphenyls (PCBs)
 - c. Contamination Remediation
- D. Performance Requirements
 - 1. Project Performance Criteria
 - a. High Voltage and Distribution System Outages
 - b. Temporary Undervoltages
 - c. Transient Overvoltages
 - d. Temporary Overvoltages
 - e. Voltage Fluctuations and Flicker
 - f. Harmonic Content/Harmonic Distortion
 - g. Phase Unbalance
 - 2. Okanogan PUD System Characteristics
 - a. Frequency
 - b. Steady-State Voltage Variations
 - c. Harmonic Voltage Distortion
 - d. Voltage Unbalance
 - e. Transient Overvoltages
 - f. Temporary Overvoltages
 - 3. Switchgear
 - a. All Voltage Levels
 - b. Circuit Breaker Operating Times
 - c. Other Fault-Interrupting Device Operating Times
 - 4. Excitation System and Power System Stabilizers
 - 5. Governor Speed and Frequency Control
 - 6. Voltage Regulation and Reactive & Distribution System Voltages
 - a. Okanogan PUD High Voltage & Distribution System Voltages
 - b. Voltage Schedules and Operation of the Project
 - 1. Synchronous Generators And Projects With Solid State Inverters
 - 2. Induction Generators
 - c. Reactive Power and Voltage Regulator Requirements
 - 1. Synchronous Generators And Projects With Solid State Inverters
 - 2. Induction Generators
 - 7. Voltage and Frequency Operation During Disturbances
- E. Protection Requirements & Guidelines
 - Refer to appropriate Appendices for different connections to Okanogan PUD's system.
 - Appendix C-1
 - Appendix C-2
 - Appendix C-3

TABLE OF CONTENTS (continued)

- F. SCADA, Metering and Telecommunication Requirements
 - 1. Supervisory Control and Data Acquisition (SCADA)
 - 2. Metering
 - a. Metering Equipment Requirements
 - b. Meter Accuracy
 - c. Instrument Transformers
 - d. Loss Compensation
 - e. Access to Metering Data
 - f. Station Service Power
 - g. Calibration of Metering Facilities
 - h. Totalized Metering & Special Meters
 - 3. Voice Communications – Phone Line and/or Radio Coverage
 - 4. Data Communications
 - a. SCADA
 - b. AGC
 - c. Energy Accounting
 - 5. Separate Telecommunications for Revenue-accuracy Metering
 - 6. Telecommunications for Protection & Transfer Trip
 - a. Speed of Operation
 - b. Equipment Compatibility

REFERENCES

APPENDICES

Appendix C-1: Protection Requirements and Guidelines – Non-Utility Generator Connection to Okanogan PUD:

This shall cover Project Sponsor generator(s) more than 5 MW or 50% of light load, whichever is the lesser value, connected to Okanogan PUD's 115 kV transmission system. Appendix C-1 shall cover the protection requirements and shall provide guidelines accommodating the generating facilities to be connected to the Okanogan PUD System. This document covers the protective relay scheme modifications for the Okanogan PUD System as well as the recommendations for the relay scheme to be installed at the Project Sponsor's generating facility.

Appendix C-2: Protection Requirements and Guidelines - Interconnection:

This document shall cover the protection requirements for bulk power interconnection between Okanogan PUD and other control area utilities other than Douglas PUD. Currently, Appendix C-2 consists of Bonneville's "Technical Requirements for the Interconnection of Facilities to the BPA Transmission Grid"

Appendix C-3: Protection Requirements and Guidelines - Load Delivery & Small Generators:

This document shall cover the protection requirements for (a) 115 kV connected load, (b) 13.2 kV load and (c) generation of up to 5 MW or 50% of light load, whichever is the lesser value, connected to Okanogan PUD's System. It includes protection requirements for load delivery for small public power companies. (Examples: Co-ops, municipal utilities, and other Public Utility Districts).

DEFINITIONS

For industry standard definitions of electric industry terminology, please refer to: The New IEEE Standard Dictionary of Electrical and Electronic Terms, ANSI / IEEE Std 100-1992 or the latest version.

For the purposes of this document the following definitions apply:

Bonneville: The Bonneville Power Administration, a federal power marketing agency responsible for, among other things, operating High Voltage transmission facilities and a Balancing Authority area in the Pacific Northwest.

Bonneville System: The integrated electrical transmission, control area, and generation facilities operated by Bonneville.

Chemical Contamination: Any level of chemical contamination that exceeds the latest Washington State Model Toxics Control Act (WAC 173-340) method A residential limits.

Connection and Operating Agreement: The document signed between Okanogan PUD and the Project Sponsor and/or Interconnecting Utility for the electrical connection between both parties.

Connection Point: The physical location on the power system of the change of ownership between Okanogan PUD and the Project Sponsor and/or Interconnecting Utility.

District: Public Utility District No. 1 of Okanogan County (Okanogan PUD).

Douglas PUD: Public Utility District No. 1 of Douglas County, a Washington State Public Utility District responsible for the planning and operation of certain High Voltage & distribution facilities located in and around Douglas County, Washington. Douglas PUD acts as Okanogan PUD's Balancing Authority.

Douglas PUD System: The integrated electrical transmission, control area, and generation facilities operated by Douglas PUD.

Okanogan PUD: Public Utility District No. 1 of Okanogan County, a Washington State Public Utility District responsible for the planning and operation of certain High Voltage & distribution facilities located in and around Okanogan County, Washington.

Okanogan PUD System: The integrated electrical High Voltage and distribution facilities owned by Okanogan PUD, including primarily 115 & 13.2 kV lines and stations.

Effectively Grounded: A system that provides an $X_0 / X, < 3$, and, $R_0 / X, < 1$ where X_0 and R_0 are zero sequence reactance and resistance, and X , is positive sequence reactance.

Generation – Distribution Connection: Technical Connection Requirements for End-User Facilities and Small Generation Facilities apply to generation Projects connected to the low-voltage side of a new or existing customer transformer that was originally designed to serve retail load, and having generating capability of greater than 100 kW, but less than i) 5 MW; and ii) 50% of the customer transformer light load.

Generation – Transmission Connection: Technical Connection Requirements for Generation & Interconnection Facilities apply to generation Projects having generating capability in excess of 100 kW and that do not otherwise meet the criteria for "Generation – Distribution Connection".

High Voltage: Nominal facility operating voltages above 34.5 kV (e.g. 115 kV).

Interconnection: High Voltage or distribution system tie point between two Balancing Authority areas.

Interconnecting Utility: The utility that owns the High Voltage or distribution system that connects a Project to Okanogan PUD's System at the Connection Point.

Load Delivery Project: Technical Connection Requirements for End-User Facilities and Small Generation Facilities apply to end-user loads with a Maximum Demand in excess of 1 MW that are connected to the Okanogan PUD System at a voltage of 115 kV and any End User Facility load that is connected to the Okanogan PUD System regardless of voltage.

NERC: The North American Electric Reliability Corporation and its successors.

NERC Reliability Standards: Standards and criteria for the reliable operation of the North American electric power system that have been adopted by the NERC Board of Trustees and are applicable to Okanogan PUD, Douglas PUD, Bonneville, and the Project.

Project: The End-User, Interconnection, or generation facility and all equipment associated with integration of the Project up to the Connection Point with the Okanogan PUD System. None of the facilities that make up the Project are owned or maintained by Okanogan PUD.

Project Operator: The entity that operates a End-User, Interconnection, or generation Facility.

Project Sponsor: The entity that owns and/or develops a new End-User, Interconnection or generation Facility.

Prudent Electric Utility Practices or Prudent Utility Practice or Prudent Engineering Practices: The generally accepted design, practices, methods, and operation of a power system, to achieve safety, dependability, efficiency, and economy, and to meet utility and industry codes, standards, and regulations.

RTU (Remote Terminal Unit): An electronic device that monitors substation or field equipment for status, analog, accumulator values. The RTU is scanned by the master station periodically for new values or for integrity checks, or, it reports to the master station "by exception". It responds to commands from the master station and provides remote contact closure(s) as necessary when Engineers remotely control equipment and devices in the field.

SCADA (Supervisory Control and Data Acquisition): A system of remote control and data acquisition used to monitor and control the High Voltage and distribution system.

Station Service: The electric supply for the ancillary equipment used to operate a generating station or substation.

Engineering Department: Okanogan PUD's Engineering Department located at 1331 Second Ave. North, Okanogan, WA responsible for High Voltage and distribution dispatch and monitoring for the Okanogan PUD System.

Temporary Overvoltage: A Temporary Overvoltage is defined as an oscillatory line-to-ground or line-to-line overvoltage lasting greater than 20 milliseconds, which is undamped or only weakly damped.

Temporary Undervoltage: A Temporary Undervoltage is defined as an oscillatory phase-to-ground or phase-to-phase voltage of 85% or less of nominal voltage lasting greater than 20 milliseconds, occurring during fault conditions.

Transient Overvoltage: A Transient Overvoltage is defined as the peak line-to-line or line-to-ground voltage during the transient conditions resulting from operation of a switching device.

Unplanned Outage: An Unplanned Outage is defined as the electrical isolation of equipment from the electrical system, without scheduling and notification of Okanogan PUD, such that the equipment is unable to perform its intended function for the duration of the isolation.

Voltage Regulation: The difference between expected maximum and minimum voltages at any particular delivery point. The Voltage Regulation limits are expressed as a percent of the nominal voltage and are defined for both normal and contingency conditions. Voltage Regulation for delivery point voltages shall not exceed the guidelines.

Voltage Unbalance: The percent deviation of one phase RMS (root mean square) voltage value from the average of all three phases' RMS voltage values.

WECC: The Western Electricity Coordinating Council or its successor, which is responsible for overseeing the reliability of the Western Interconnection.

Western Interconnection: The interconnected electric systems of the western portions of the United States, Canada, and Mexico, and which operate synchronously with each other.

A. Scope

The technical requirements contained herein apply to all permanent or temporary Generation – Transmission Connection and Interconnection Projects on the Okanogan PUD System. It also applies to existing Generation – Transmission Connection and Interconnection Projects that are connected to the Okanogan PUD System through interim agreements.

The Okanogan PUD System interconnects with the Bonneville System and Douglas PUD System at various locations. Douglas PUD also serves as the Balancing Authority for the Okanogan PUD System. Larger Projects connecting to the Okanogan PUD System could have an effect on the Douglas System and/or Bonneville System, as well as Douglas PUD's Balancing Authority area. As a result, a Project may also be subject to all or portions of Douglas PUD's "Facility Connection Standards", Bonneville's "Line and Load Interconnection Procedures", "Generator Interconnection – Large" (Business Practice), and "Technical Requirements for Interconnection with the BPA Transmission Grid". The Project location, interconnection voltage, transmission access requirements, and capacity will dictate the extent to which the Douglas PUD and/or Bonneville procedures and technical requirements apply to a given Project. Okanogan PUD will work with the Project Sponsor, Douglas PUD, and Bonneville to resolve any discrepancies arising from the use of multiple procedures and technical requirements applicable to a given Project.

The location of the Connection Point and the impacts on the Okanogan PUD System, or another utility's system, determine the specific technical requirements applicable to a given Project. The Project shall not degrade the safe operation, integrity, or reliability of the Okanogan PUD System or the Western Interconnection.

1. Connection and Operating Agreement

Okanogan PUD and the Project Sponsor or Project Operator will execute a Connection and Operating Agreement before Okanogan PUD will authorize the Project Sponsor or Project Operator to commence commercial operation of the Project.

The signing of the Connection and Operating Agreement establishes the Project Sponsor or Project Operator's right to connection/interconnect to the Okanogan PUD System at the Connection Point, but the Connection and Operating Agreement in no way provides or guarantees transmission service across the Okanogan PUD System. Okanogan PUD will provide transmission service under the terms and conditions of a transmission agreement between Okanogan PUD and the Project Sponsor, Interconnecting Utility, or other entity that wishes to move power between the boundaries of the Okanogan PUD System and the Connection Point.

2. Load Following, Regulation, and Reserves

Because Okanogan PUD is embedded in the Douglas PUD Balancing Authority area, the Project Sponsor or the Project Operator may negotiate an agreement for provision by/to Douglas PUD of load following, load regulation, and/or reserve products. Okanogan PUD reserves the right to participate in such negotiations to ensure that Project operation has no adverse effect on the cost to Okanogan PUD of Douglas PUD load following, load regulation, reserve, or any other power sale products that Okanogan PUD requires for service to its other customers.

3. Applicable Codes, Standards, Criteria and Regulations

The Project, to the extent applicable, shall comply with those codes, standards, criteria and regulations listed in the “REFERENCES” section of this document, as well as any other codes, standards, criteria and regulations that may apply to the Project.

4. Safety, Protection, and Reliability

The Project Sponsor is required to submit design and preliminary relay settings for the protection of the Project’s equipment. The submittal shall be at least 2 months before the Project Sponsor anticipates initial operation of the Project. Okanogan PUD, after consultation with the Project Sponsor and other relevant parties, particularly Douglas PUD and/or Bonneville, shall make the sole and final determination as to whether the Okanogan PUD System is properly protected from any problems that the Project might cause. The Project Sponsor is responsible for correcting such problems before initial operation begins. The Project Sponsor is responsible for safety, protection, and reliability on the Project side of the Connection Point. See the appropriate Appendix on Protection.

5. Non-Okanogan PUD Responsibilities

Project Sponsors and Project Operators shall comply with NERC & WECC Reliability Standards, the Douglas PUD “Facility Connection Requirements”, the Bonneville “Line and Load Interconnection Procedures”, “Generation Interconnection Procedures – Large” (Business Practice), “Technical Requirements for Interconnection with the BPA Transmission Grid” and Transmission Operator (TOP) requirements. At the Project’s expense, the Project Sponsor is responsible for the planning, design, construction, reliability, protection and safe operation of non-Okanogan PUD-owned facilities. The design and operation of the Project is subject to applicable local, state and federal statutes and regulations.

6. Cost of Analysis, Connection Studies, and Facility Studies

The Project Sponsor shall reimburse Okanogan PUD, or its designated consultant(s), for the actual costs to perform any work and/or analysis associated with the Project, including the cost of the Connection Study and Facility Study.

7. Approval and Acceptance

The terms “approve”, “approved” and “approval” used in this document means acceptance. Approval by Okanogan PUD does not mean that Okanogan PUD endorses or is to be responsible for the safety or reliability or damage-free operation of a Project’s design, facility, construction or equipment.

B. Connection Study and Facility Study

A Project Sponsor that desires to connect a Project to the Okanogan PUD System shall follow the procedures contained in the “Procedures and Requirements for Okanogan PUD Electric System Interconnection”. The Project Sponsor first requests that Okanogan PUD conduct a Connection Study and executes a Connection Study Agreement. Okanogan PUD, or a consulting company approved by Okanogan PUD, performs the Connection Study in two phases – a Feasibility Study and a Detailed Connection Study. The Project Sponsor shall supply information on the location, voltage, and other pertinent Project connection requirements to determine the effect the Project will have on the Okanogan PUD System, the Douglas System, the Bonneville System, and the rest of the Western Interconnection. The data that the Project Sponsor is required to provide to enable the completion of these studies are listed in the “Required Project Sponsor-Supplied Information” section.

After review of the results of the Connection Study, the Project Sponsor may elect to proceed with a Facility Study to determine modifications and associated costs to the Okanogan PUD System, the Douglas System, and/or the Bonneville System to accommodate the Project. The Facility Study will also address metering requirements, protective relaying, substation grounding, communication, and SCADA requirements.

Proposals for interconnection with other Balancing Authority areas shall require coordination of studies among the Project Sponsor, Okanogan PUD, Balancing Authority (if different from the Project Sponsor), and Douglas PUD.

1. Connection Configuration

Okanogan PUD shall evaluate on a case-by-case basis whether a Project shall be connected to the Okanogan PUD System by tapping an existing transmission or distribution line or by connecting directly into an existing transmission or distribution substation.

A new transmission switching station may be built in the middle of an existing transmission line. Okanogan PUD’s 115 kV transmission facilities typically move power from Bonneville or Douglas PUD substations to Okanogan PUD distribution substation loads.

Connection options are dependent upon many factors, including location of the desired Connection Point relative to existing Okanogan PUD transmission facilities, the size of the Project’s generation or desired Interconnection capability, present line loading, and other requirements of the Project. The most feasible option(s) shall be considered in the Connection Study, with the most economic option that meets all requirements being selected.

2. Power Flow, Short Circuit, and Stability Analysis

The Project is “modeled” by Okanogan PUD (or its consultant), Douglas PUD, and/or Bonneville using the data provided by the Project Sponsor. System simulations are performed to determine the impact of the Project on the High Voltage and/or distribution system. The Project Sponsor shall provide the expected source and sink of energy related to the Project. The primary intent is to determine if the Project causes any violations of Okanogan PUD, Douglas PUD and/or Bonneville’s planning & reliability criteria. A summary of these study modules is shown below:

a. System Rating and Voltage Screening – power flow analysis

The purpose of this study is to ensure that the connection of the Project does not create any system loading or voltage levels outside of the limits in this document or

in Okanogan PUD's planning & reliability criteria. Project information obtained from the Project Sponsor is used to model the Project. System simulation tools are used to model a wide range of High Voltage and distribution system operating conditions to determine the system loading and voltage level changes created by the Project on the Okanogan PUD System.

b. Transfer Capability – power flow analysis

The purpose of this study is to ensure that the connection of the Project does not reduce the ability of the High Voltage system to transport power over long distances between and among control areas. Joint studies with other utilities, particularly Bonneville and Douglas PUD, may be necessary. Power transfers are simulated across the Okanogan PUD System, Douglas PUD, and/or Bonneville System in various directions to determine how the Project affects Okanogan PUD's ability to transfer power across its system.

c. Fault Duty – short circuit analysis

The purpose of this study is to determine the changes in available fault duty caused by the Project. Transformer, line and generator impedances, and the circuit configuration are needed to create the model for the study. The data is inserted into the current Okanogan PUD, Douglas PUD and/or Bonneville models. The new generation buses and those local to it are faulted to allow comparison with fault conditions prior to the addition of the Project. The study results are reviewed to ensure that no equipment ratings shall be exceeded and are utilized for determining the size of grounds used for personnel protection for conducting de-energized line and station work.

d. Stability – stability analysis

Dynamics software is used to evaluate the impact of the new system configuration and additional generating capacity on system stability. In addition to the normal steady state model data, generator impedances and time constants, turbine governor data, and voltage regulator data are needed to create a model for the study. The new generation buses and those local to it are faulted to evaluate system stability with and without the Project. Study results are evaluated to ensure system stability shall be maintained and that any necessary changes to relaying or controls are identified. See the "General Requirements" section for more detail on generator controls.

3. Protection

After studying the possible ways to connect the Project to the Okanogan PUD System, the protective requirements shall be determined. This shall include an impedance model at the Connection Point (short-circuit data), protective changes to the transmission and/or distribution system, protective requirements for the Project and any special protective needs for the Project. See the "General Requirements" and "Protection Requirements & Guidelines" sections for more details on these requirements. Okanogan PUD may need to coordinate protection requirements with Douglas PUD and Bonneville.

4. Power Quality and Reliability

There is a very diverse set of users connected to the Okanogan PUD System, with different system requirements. In the past, most customers were only concerned with extended interruptions. However, the increased use of highly sensitive power electronic devices within all customer sectors has changed the definition of reliability. Due to the sensitivity of many industrial and commercial loads, such as adjustable speed drives (ASDs) and computer controlled processes, reliability is no longer only defined by the frequency and duration of sustained interruptions. There are many power quality variations other than sustained interruptions that could constitute inadequate service for the proper operation of customer equipment. Variations such as Voltage Unbalance, Voltage Flicker, Harmonic Distortion, Transient Overvoltages, Temporary Overvoltages and steady-state Voltage Regulation can adversely affect customer processes.

The challenge for Okanogan PUD is to design and operate the system such that it meets the requirements of this diverse set of users. To meet this challenge, Okanogan PUD or its consultant(s) performs studies to determine the power quality and reliability impacts of any new Project on the Okanogan PUD System at the Connection Point. The intent of these studies is to ensure that the connection of the Project does not compromise the reliability and integrity of the Okanogan PUD System.

The studies performed for each new Project may include:

a. Voltage Unbalance

The purpose of this study is to ensure that the operation of any new Project does not create a Voltage Unbalance condition in excess of the limits provided in the “Performance Requirements” section. Project information obtained from the Project Sponsor is added to the power system model. Using power system simulation tools, studies are performed over a wide range of transmission and distribution system operating conditions to determine the range of Voltage Unbalance created by the Project at the Connection Point.

b. Voltage Fluctuations or Voltage Flicker

The purpose of this study is to ensure that the operation of any new Project does not create Voltage Fluctuations or Voltage Flicker in excess of the limits provided in the “Performance Requirements” section. Project information obtained from the Project Sponsor is added to the power system model. Using power system simulation tools, studies are performed over a wide range of transmission and distribution system operating conditions to determine the range of Voltage Fluctuations and Voltage Flicker created by the Project at the Connection Point.

c. Harmonic Distortion

The purpose of this study is to ensure that the operation of any new Project does not create harmonic current injections in excess of the limits provided in the “Performance Requirements” section. Project information obtained from the Project Sponsor is added to the power system model. Using power system simulation tools, studies are performed over a wide range of transmission and distribution system operating conditions to determine the range of harmonic distortion created by the Project at the Connection Point.

d. Transient Overvoltage

The purpose of this study is to ensure that the operation of any new Project does not create a transient overvoltage condition in excess of the limits provided in the “Performance Requirements” section. Project information obtained from the Project Sponsor is added to the power system model. Using power system simulation tools studies are performed over a wide range of transmission and distribution system operating conditions to determine the range of Transient Overvoltages created by the Project at the Connection Point.

e. Temporary Overvoltage

The purpose of this study is to ensure that the operation of any new Project does not create a Temporary Overvoltage condition in excess of the limits provided in the “Performance Requirements” section. Project information obtained from the Project Sponsor is added to the power system model. Using power system simulation tools, studies are performed over a wide range of transmission and distribution system operating conditions to determine the range of Temporary Overvoltages created by the Project at the Connection Point.

f. Temporary Undervoltage

The purpose of this study is to ensure that the operation of any new Project does not create a Temporary Undervoltage condition in excess of the limits provided in the “Performance Requirements” section. Project information obtained from the Project Sponsor is added to the power system model. Using power system simulation tools, studies are performed over a wide range of transmission and distribution system operating conditions to determine the range of Temporary Undervoltages created by the Project at the Connection Point.

g. Insulation Coordination

The purpose of this study is to ensure that the operation of any new Project does not create a situation that exposes Okanogan PUD-owned transmission and distribution equipment to a condition in excess of the limits provided in the “Performance Requirements” section. Project information obtained from the Project Sponsor regarding insulation coordination studies is reviewed and shall be approved by Okanogan PUD prior to connection. Okanogan PUD may perform independent studies verifying that the models and assumptions used by the Project Sponsor are appropriate for their application.

5. Changes to Project Sponsor-Supplied Information

If the Project Sponsor or Project Operator identifies any change in data previously supplied pursuant to these connection requirements, the Project Sponsor or Project Operator shall notify Okanogan PUD in writing within 30 days. This notification shall include:

- The time and date at which the change became, or is expected to become effective.
- If the change is only temporary, an estimate of the time and date at which the data shall revert to the previously supplied form.

A request for a change in Connection Point to the Okanogan PUD System, level of generation, or expected sink shall be submitted as a new request. A new Connection Study or Fa-

cility Study completion date shall be negotiated with the Project Sponsor or Project Operator when Project data is changed during the study process.

6. Required Project Sponsor-Supplied Information

In order to complete the Connection Study and the Facility Study, the Project Sponsor shall provide the following Project information:

- a. Company name and contact name
- b. Address
- c. Phone number, fax number, e-mail address of contact name
- d. Effective date of new connection or modification
- e. Proposed geographic location and plot plan providing orientation of the Project on the site (USGS map)
- f. Electrical Connection Point
- g. Voltage level of proposed connection
- h. One-line diagram of Project
- i. Start-up Date
- j. Commercial operation date
- k. Contract path & source and sink for the energy
- l. Duration of power purchase contract
- m. Expansion plans
- n. Number and type of units
- o. Plant start-up load
- p. Fuel type
- q. Total generation capability (MW) – Summer, Spring and Winter ratings
- r. Power factor
- s. Generator data (for each generator)
 1. Manufacturer
 2. Base MVA
 3. Maximum MVA
 4. Rated MW (Summer & Winter)
 5. Rated kV
 6. Rated power factor
 7. % reactance- synchronous, sub-transient & transient
 8. Capability curve data
 9. Auxiliary load data
 10. *Dynamic modeling data - H, Ra, Xd, Xq, X'd, X'q, X''d, X''q, XI, T'do, T'qo, T''do, T''qo, S(1.0), S(1.2)
 11. *Governor & excitation system models - PTI format (P/SSE Version 25.4)

Note: "**: This data shall be verified and supplied to Okanogan PUD at the time of the commissioning. If the data is different from original data, Okanogan PUD has the right to request additional stability studies.

- t. Step-up transformer data
 1. Manufacturer
 2. Connection (delta-wye)
 3. KVA ratings of all windings
 4. H winding kV
 5. X winding kV
 6. Y winding kV
 7. Transformer neutral load in ohms
 8. Impedance (%Z) and load losses (W) @kVA for all tap combinations of H-X, H-Y, & X-Y
 9. No load losses and magnetizing current

- u. Other transformer ratings, connections, voltage taps, impedances, and grounding
- v. Transmission & distribution line voltage, conductor rating, impedance, length
- w. Lightning protection designs for Transmission & distribution lines and stations
- x. Special requirements (e.g. sensitive equipment, dual feeds, etc.)
- y. Interconnection schemes and equipment (ring bus, breaker and a half, etc.)
- z. Relay schemes, relay settings, protection equipment
- aa. Maintenance schedules and procedures
- bb. Station service requirements

C. General Requirements

1. Safety

All safety and operating procedures for Project equipment shall be in compliance with the Occupational Safety and Health Administration (OSHA) standard 29 CFR 1910.269, the National Electrical Code (NEC), Washington State Administrative code (WAC rules), National Electric Code (NEC), the Washington Industrial Safety and Health Administration (WISHA) standard, and the Project Sponsor's safety manuals.

a. Isolation Requirements

The Project Operator shall not energize any Okanogan PUD System line or equipment unless the Okanogan PUD Engineering Department, or Douglas PUD System Operations Office, specifically approves energization. If, for any reason, a protective device operation separates the Project from the Okanogan PUD System, the Project Operator shall contact the Okanogan PUD Engineering, before attempting to restore the connection to the Okanogan PUD System.

The Project Sponsor shall provide a disconnect switch at the Connection Point to physically and visibly isolate the Project from the Okanogan PUD System. With the consent of Okanogan PUD and the Project Sponsor, the disconnect switch may be installed at another location, other than the Connection Point, provided that the purpose described herein is satisfied. The device:

1. Shall be accessible by, and under, Okanogan PUD Engineering Department jurisdiction.
2. Shall be gang-operated and lockable in the open position by Okanogan PUD.
3. Shall be suitable for safe operation under the conditions of use.
4. Shall not be operated without advance notice to either party, unless an emergency condition requires that the device be opened to isolate the Project.

At its discretion, Okanogan PUD personnel may open the switch:

1. If it is necessary for the protection of Okanogan PUD maintenance personnel when working on de-energized circuits.
2. If Project equipment or Okanogan PUD System equipment presents a hazardous condition.

Consideration shall be given as to the design and capacity of the switch on a case-by-case basis. The switch is required for safety and it shall not interrupt excessive load or charging current. However, a suitable switch for the safety requirements herein described may also be used to provide for other operational purposes.

b. Generation Served by the Project

The Project Sponsor shall maintain a record of all generation customers served by the Project and such record shall be made available to Okanogan PUD annually or upon request. For the requirements of energized line maintenance or line construction on the Okanogan PUD System, the Project Sponsor shall ensure that all genera-

tion customers served by the Project shall disconnect their generation upon request by Okanogan PUD.

c. Chemical Hazards

The Project Sponsor shall supply a list to Okanogan PUD identifying all hazardous chemicals used in equipment installed by the Project Sponsor in Okanogan PUD facilities or rights-of-way. The list shall include hazardous chemicals in use in Project Sponsor facilities that will be accessed by Okanogan PUD employees during the course of the Connection and Operation Agreement and used by the Project Sponsor to maintain its equipment. A current Material Safety Data Sheet (MSDS) shall be supplied by the Project Sponsor to Okanogan PUD for each chemical on the list. The list shall include the name and volume of the chemical and shall include, but not be limited to, mineral oil, sulfur hexafluoride, Trichloroethane, etc. The Project Sponsor shall insure that all Project equipment is free of Polychlorinated Biphenyls (PCB's), or other hazardous chemicals as prohibited by State or Federal regulations.

2. Connection Point Considerations

a. General Configurations and Constraints

Integration of Projects into power systems usually falls into one of the following three categories:

1. Connection into an existing transmission substation.
2. Connection at High Voltage to a transmission line by building a new switching station in the vicinity of the Project.
3. Connection on the low-voltage side of a new or existing customer service transformer that was originally designed to serve load. "Technical Connection Requirements for Load Delivery Facilities and Small Generation Facilities" apply to Projects having generating capability of less than 5 MW and 50% of light load, whichever is the lesser value.

b. Other Considerations

Below are some of the other factors Okanogan PUD will consider when evaluating Project proposals:

1. Equipment

Existing electrical equipment, such as transformers, power circuit breakers, disconnect switches, and line conductors were purchased based on the duties and capacity limits expected in response to system additions identified in any plans. However, the connection of a new Generation – Transmission Connection or Interconnection Project could overload specific equipment, thereby requiring equipment replacement prior to Project operation.

2. Outage Coordination & Maintenance

Okanogan PUD operates and maintains its system to provide reliable and safe customer service at all times. Project integration requires that the equipment at the Connection Point not restrict timely outage coordination, automatic switching, or equipment maintenance scheduling. Preserving reliable service to all Okanog-

an PUD customers is essential. When this condition is violated, the Project shall provide additional switchgear, equipment redundancy, or bypass capabilities at the Connection Point for acceptable operation of the system.

3. Atmospheric & Seismic

The effects on the Okanogan PUD System of wind storms, floods, lightning, altitude, temperature extremes, and earthquakes shall be considered in the design and operation of the Project. The Project Sponsor is responsible for determining that the appropriate standards are met, including, but not limited to, the Uniform Building Code (UBC), the National Electric Safety Code (NESC), and the National Electrical Code (NEC). Depending on Project location, size, type, and importance, Okanogan PUD may request that additional capabilities be designed into the Project.

3. Substation Grounding

Each generation site and/or interconnecting substation shall have a ground grid that solidly grounds all metallic structures and other non-energized metallic equipment. This grid shall limit the ground potential gradients to such voltage and current levels that shall not endanger the safety of people (step and touch potential) or damage equipment which are in, or immediately adjacent to, the station under normal and fault conditions.

If the Project is physically close to another substation, the two ground grids should be connected unless noted otherwise below. The interconnecting cables shall have sufficient capacity to handle fault currents and control ground grid voltage rises. Okanogan PUD shall approve any connection to a Okanogan PUD substation ground grid. From time to time, Okanogan PUD may test the ground connection between Okanogan PUD and the Project. If it is found that the ground connection is inadequate due to corrosion, both parties shall be equally responsible in reinforcing the ground connection so as to meet the intent of this requirement.

If the ground grids are isolated for operational reasons, there shall be no metallic ground connections between the two substation ground grids. Cable shields, cable sheaths, Station Service ground sheaths, and overhead High Voltage shield wires can all inadvertently connect ground grids. Fiber-optic cables are required for telecommunications and control between two substations to maintain isolated ground grids. In the case where the Project is physically close to another substation but the ground grids are isolated, the Project Sponsor shall demonstrate that the ground grids are properly isolated in compliance with all applicable codes and standards. Okanogan PUD prefers to connect static wires on incoming transmission lines to the station ground grid. If the Project Sponsor prefers not to connect static wires on incoming transmission lines to the station ground grid, the Project Sponsor shall notify Okanogan PUD in writing and demonstrate that relay performance, lightning protection, and personnel safety are not compromised by isolating the static wires from the station ground grid.

The Project ground grid shall be designed to ANSI/IEEE Std. 80-1986, IEEE Guide for Safety in AC Substation Grounding, and shall be measured in accordance with IEEE -81 Part 1: Guide for Measuring Earth Resistivity, Ground Impedance, and Earth Potentials and Part 2: Measurement of Impedance and Safety Characteristics of Large, Extended or Interconnected Grounding Systems. Project grounding requirements shall also comply with the National Electrical Safety Code, ANSI/IEEE-665 Guide for Generating Station Grounding, IEEE-837 Standard for Qualifying Permanent Connections Used in Substation Grounding, IEEE-487 Protection of Wire-Line Communication Serving Electric Power Stations, ANSI/IEEE 367-1987 IEEE Recommended Practice for Determining the Electric Power Station Ground Po-

tential Rise and Induced Voltage from a Power Fault, and any applicable state and local codes.

4. Insulation Coordination

Power system equipment is designed to withstand voltage stresses associated with expected operation. Connection Studies include the evaluation of the impact of the Project on equipment insulation coordination. Okanogan PUD identifies additions required to maintain an acceptable level of Okanogan PUD System availability, reliability, equipment insulation margins, and safety.

Voltage stresses such as lightning surges, switching surges, Temporary Overvoltages, and normal 60Hz voltages affect equipment duty. Remedies depend on the equipment capability and the type and magnitude of the stress. Below are the requirements that shall be met to connect to the Okanogan PUD System. In general, stations shall be protected against lightning and switching surges. Typically this includes station shielding against direct lightning strokes, surge arresters on all wound devices, and shielding on the incoming lines.

a. Lightning Surges

Lightning related causes are not exempt from the "Performance Requirements" section. Although it is not always cost effective to design and build a power system to withstand every possible lightning strike, it has been demonstrated that with proper design and installation procedures, the effects of lightning can be mitigated to achieve a reliability level equal to or exceeding the requirements of the "Project Performance Criteria" section. Techniques used to help control lightning related events on High Voltage lines include proper use of shield wires, insulation levels, low resistance grounding, and surge arresters. Techniques used to help control lightning related outages in substations include substation shielding, proper arrester applications, and shielding of incoming High Voltage lines.

If the Project proposes to tap a Okanogan PUD transmission line that is shielded, the new tap line shall also be properly shielded for at least 0.5 mile for 115 kV from the Okanogan PUD station. If any stations are within 1.0 to 0.5 mile of the Okanogan PUD System, these also shall be properly shielded from direct lightning strikes. The Project Sponsor shall be able to demonstrate proposed designs for any transmissionlines and substations shall perform within the limits for service interruptions as stated in the "Performance Requirements" section.

For transmission line design, an industry recognized lightning performance estimating algorithm shall be used to demonstrate acceptable performance of the design. The Project Sponsor shall make reasonable assumptions based on the area that the transmission line shall be installed including ground flash density and grounding conditions. The Project Sponsor shall be able to provide an alternative plan if the ground conditions required for acceptable performance are not achieved during construction of the transmission line.

For substation design, the Project Sponsor shall be able to demonstrate their proposed designs shall operate within the performance requirements. The shielding designs and arrester applications shall adhere to applicable IEEE standards. In addition, any normally open points that are subject to voltage "doubling" of incoming lightning surges shall be considered and protected accordingly so the Performance Requirements are not violated.

b. Temporary Overvoltages

Temporary Overvoltage's can last from seconds to minutes, and are not characterized as surges. These overvoltages are usually present during faults and other abnormal system conditions. The Okanogan PUD System is considered Effectively Grounded at all voltages. A system that loses proper grounding may be impedance grounded and can have line to ground voltages approaching 1.73 times normal line to ground voltage during fault conditions on unfaulted phases. Therefore, Okanogan PUD requires that the Project Sponsor periodically evaluate and maintain Project grounding conditions in order to ensure system integrity and performance.

When generation is connected to the low-voltage side of a delta-wye grounded (D-YG) transformer, remote end breaker operations initiated by the detection of faults on the high-voltage side can cause overvoltages that can affect personnel safety and damage equipment. In these instances, Okanogan PUD shall require the Project to rapidly separate the generator from the step-up transformer by tripping a breaker using either transfer trip or local relay detection of overvoltage condition. See the appropriate Appendix on Protection.

A system study may be performed for each Project based on the point on the Okanogan PUD System that is being connected. The Project Sponsor shall be supplied the system characteristics needed to calculate the Temporary Overvoltage's that need to be considered. Gapless metal-oxide surge arresters are especially sensitive to system Temporary Overvoltage's and Okanogan PUD shall review and approve the specification of arresters used to ensure proper application.

c. Normal Operating Voltages

The Okanogan PUD System voltages are normally operated within the limits specified in the "Performance Requirements" section of this document. Insulation coordination usually does not need to consider this operating range once lightning and switching surge requirements are met; however, in highly contaminated areas, special consideration and additional insulation requirements are required for proper insulation coordination. The Project Sponsor is responsible for determining whether special insulation requirements are needed for its system.

5. Inspection, Verification, Testing, Calibration and Maintenance

At the Connection Point, the inspection, verification, testing, calibration and maintenance responsibilities by the two entities are shown in the diagram Figure 1 (p. 34).

The Project Sponsor has full responsibility for the verification, testing, calibration, and maintenance of its equipment up to the Connection Point, consistent with the Connection and Operating Agreement.

a. Project Sponsor - Pre-energization Inspection, Verification and Testing

The Washington State Department of Labor and Industries (L&I) requires permitting and inspection of electrical wiring for compliance with the latest version of the National Electrical Code (NEC). Okanogan PUD (or its independent contractor) shall inspect Project Sponsor's facility when it is connected to Okanogan PUD's meter(s). The Project shall be energized only after successful completion of all inspections.

Before initial Project energization, the Project Sponsor or Project Operator shall develop a verification and test plan for pre-energization and energization testing. This plan shall include provisions for testing protective equipment that comply with the NERC Reliability Standards (PRC-001-1 and PRC-003-1). Okanogan PUD (or its independent contractor), and Douglas PUD shall review and approve the test plan prior to the test. Okanogan PUD may require additional tests. The Project Sponsor shall make available to Okanogan PUD all drawings, specifications, and test records of the Project equipment pertinent to connected operation.

b. Project Sponsor - Equipment Maintenance

The Project Sponsor or Project Operator shall implement a maintenance program for the Project equipment. The program shall be designed and executed in a manner to ensure the proper operation of the Project equipment. The program shall be based on time or on other factors, including performance levels or reliability. Appropriate equipment performance data shall be collected and maintained by the Project Sponsor or Project Operator. Okanogan PUD reserves the right to review the Project's maintenance program. Maintenance records of the Project equipment pertinent to interconnected operation shall be made available to Okanogan PUD upon request.

6. Station Service

See "Connection Agreement for Generation and Interconnection Facilities" for details on Station Service.

7. Fault Interruption, Synchronization, and Blackstart

a. Fault Interruption

The Project Sponsor shall ensure that proper current-interrupting, isolating equipment is acquired and installed at the Connection Point for the purposes of protecting the Project from faults or other undesirable conditions on the transmission system, and to protect the transmission system from faults internal to the Project.

During emergency conditions, the Project Operator's first duty is to ensure safety guidelines are achieved and to protect station equipment. The Project Operator shall have a Okanogan PUD-approved set of procedures on file at the Engineering Department, and at the Project that are to be followed when separating from, and reconnecting to, the transmission or distribution system. These procedures, jointly developed by the Project Operator and Okanogan PUD typically include:

1. A frequency limit duration table
2. A circuit breaker operation procedure
3. A generator loading/circuit protection procedure
4. A set of unit operating conditions that shall be maintained to prevent damage to the unit(s) and/or the transmission or distribution system.

Unless authorized by Okanogan PUD's Engineering Department, or Douglas PUD's System Operator, the Project Operator shall NOT

- Energize any equipment

- Connect to any energized equipment
- Parallel any generation to the system

If, for any reason, Okanogan PUD is disconnected from the Project (through a fault condition, line switching, etc.), the Project breaker(s) shall be tripped and not reclose until approved by the Engineering Department.

b. Synchronization

The Project Operator shall be responsible for synchronizing its equipment to the Okanogan PUD System. During all other conditions, the generator shall have Okanogan PUD approved procedures in place when connecting to the system. For automatic or manual synchronization, a sync-check relay shall be installed to assure that the unit is not connected to the energized power system out of synchronization.

c. Blackstart

Blackstart is the condition when a unit of a generation for the Project has the capability to start up under local power (usually with the assistance of battery back-up or a back-up generator), in isolation from the rest of the electric system. Blackstart capability is needed in the rare event of a system restoration emergency. Depending on the size and location of a Project, Okanogan PUD, Douglas PUD, Bonneville, and the Project shall agree if a blackstart service is needed from that Project. It is generally not needed for small generators or for Projects in close proximity to other major generation. If the Project is supplying blackstart capability to the Okanogan PUD System, the Douglas PUD System and/or the Bonneville System, then it shall be a participant in Douglas PUD's or Bonneville's emergency guidelines to restore the transmission system following an electrical disturbance. In the event of a local or wide-spread blackout, those guidelines shall be followed to aid in the restoration of the system. If for any event, generation is not running and the Project becomes completely de-energized, the Project Operator shall advise the Okanogan PUD Engineering Department of its status and await further Engineering Department instruction.

Some issues Douglas PUD and Bonneville consider when determining whether to request the capability of a Project to provide blackstart capability include the following:

1. Proximity to other generation (i.e. Can blackstart capability be provided more efficiently from another Project?)
2. Location of the Project on the High Voltage system (i.e. Is the Project near major load centers and far from other generation?)
3. Cost of on-site start-up
4. Periodic testing to ensure personnel training and capability

8. Environmental Considerations

a. Property Contamination

The Project Sponsor shall be responsible for identifying all chemical contamination on its properties that may be accessed by Okanogan PUD personnel for the duration of the Connection and Operating Agreement.

b. Polychlorinated Biphenyls (PCBs)

The Project Sponsor shall not use electrical equipment that contains PCBs.

c. Contamination Remediation

The Project Sponsor or the Project Operator shall notify Okanogan PUD immediately of any releases of hazardous chemicals to Okanogan PUD property or facilities by Project Sponsor equipment or activities. Okanogan PUD shall notify the Project Sponsor or the Project Operator if Okanogan PUD personnel are the first to notice the release. The Project Sponsor shall respond immediately to mitigate and remediate the release in accordance with all federal, state, and local requirements and especially with WAC 173-340. The Project Sponsor shall restore all remediated areas to their former status.

D. Performance Requirements

All Projects shall be properly designed, constructed, operated and maintained to avoid degrading the reliability of the Okanogan PUD System and the Western Interconnection. A Project shall comply with the "Project Performance Criteria", listed below, and shall be able to operate satisfactorily within the limits defined in the "Okanogan PUD System Characteristics" section below, in order to be considered properly connected. The Project Sponsor or Project Operator is expected to demonstrate, through monitoring, that the Project meets the performance criteria. The Project outages and undervoltage's noted below shall be continuously monitored. The remaining criteria shall be met and considered in the design and operation of the Project although these do not necessarily have to be continuously monitored. If problems are suspected at any time, Okanogan PUD may require the Project Sponsor and/or Project Operator to demonstrate, through monitoring, that the performance of the Project at the Connection Point meets these requirements.

If the requirements are not met, the Project Sponsor or Project Operator shall demonstrate to Okanogan PUD a plan to improve and meet the performance criteria. Additional relay and control requirements may be developed and enforced by Okanogan PUD after connection is made if these performance criteria are violated.

1. Project Performance Criteria

To ensure the reliability and integrity of the electrical system, all Projects shall meet the Project performance criteria at the Connection Point. The Project shall not operate its equipment or system to harm the Okanogan PUD System or its customers, the Douglas PUD System, or the Bonneville System. The following section details the "Project Performance Criteria":

a. Transmission and Distribution System Outages

The Project shall not operate its equipment or system in such a manner as to cause the Unplanned Outage of any Okanogan PUD System components more than once in any twelve month period, more than three times in any five year period, or more than five times in any ten year period.

b. Temporary Undervoltages

The Project shall not operate its equipment or system in such a manner as to cause Temporary Undervoltages at the Connection Point more than twice in any twelve month period, more than five times in any five year period, or more than eight times in any ten year period. Undervoltages due to non-fault events are covered in the "Voltage Fluctuations and Flicker" requirements below. Multiple Temporary Undervoltage conditions occurring within one minute shall be considered the same event

c. Transient Overvoltages

The Project shall not operate its equipment or system in such a manner as to cause a peak transient voltage at the Connection Point greater than or equal to 140% of the nominal peak voltage. Any transient voltage condition caused by the operation of the Project's equipment or system that results in a peak transient voltage greater than or equal to 140% of the nominal peak voltage at the Connection Point is not allowed.

d. Temporary Overvoltages

The Project shall not operate its equipment or system in such a manner as to cause a Temporary Overvoltage at the Connection Point greater than or equal to 120% of the nominal system voltage. Any temporary voltage condition caused by the operation of the Project's equipment or system that results in a Temporary Overvoltage greater than or equal to 120% of the nominal system voltage at the Connection Point is not allowed.

e. Voltage Fluctuations and Flicker

The allowable voltage fluctuation limits as a function of the frequency of occurrence at the Connection Point are provided in Okanogan PUD "Voltage Flicker" standards.

f. Harmonic Content/Harmonic Distortion

The maximum allowable harmonic current injections (percentage harmonic distortion at each frequency as a function of load current) at the Connection Point for Projects connected at 115 kV and 13.2 kV are defined in Table 1 and Table 2. Operation of the Project in such a manner as to create a condition where the harmonic current injection at the Connection Point exceeds the limits provided for in Tables 1 and Table 2 for a duration greater than or equal to one hour on any single day or exceeds 150% of the limits provided for the given connection voltage for a duration greater than five minutes on any two days during a six month period is not allowed.

Table 1. Current Injection Harmonic Distortion Limits
Connection Point Voltage 63,508 V to 132,790 V

Individual Harmonic Order (Odd Harmonics)						
I_{sc} / I_{load}	$h < 11$	$11\Omega h < 17$	$17\Omega h < 23$	$23\Omega h < 35$	$h > 35$	TDD
<20	2.0%	1.0%	0.75%	0.3%	0.15%	2.5%
20<50	3.5%	1.75%	1.25%	0.5%	0.25%	4.0%
50<100	5.0%	2.25%	2.0%	0.75%	0.35%	6.0%
100<1000	6.0%	2.75%	2.5%	1.0%	0.5%	7.5%
>1000	7.5%	3.5%	3.0%	1.25%	0.7%	10.0%

Notes: Even harmonics are limited to 25% of the odd harmonic limits above

Current distortions that result in DC offset are not allowed

I_{load} is the maximum load current (fundamental frequency component) at the Connection Point

I_{sc} is the maximum short-circuit current at the Connection Point

TDD (Total Demand Distortion) is the total harmonic current distortion expressed in % of maximum demand load current

Table 2. Current Injection Harmonic Distortion Limits
Connection Point Voltage 120 V to 63,508 V

Individual Harmonic Order (Odd Harmonics)						
I_{sc} / I_{load}	$h < 11$	$11\Omega h < 17$	$17\Omega h < 23$	$23\Omega h < 35$	$h > 35$	TDD
<20	4.0%	2.0%	1.5%	0.6%	0.3%	5.0%
20<50	7.0%	3.5%	2.5%	1.0%	0.5%	8.0%
50<100	10.0%	4.5%	4.0%	1.5%	0.7%	12.0%
100<1000	12.0%	5.5%	5.0%	2.0%	1.0%	15.0%
>1000	15.0%	7.0%	6.0%	2.5%	1.4%	20.0%

g. Phase Unbalance

Unbalanced phase voltages and currents can affect protective relay coordination and cause high neutral currents and thermal overloading of transformers. To maintain the reliability and integrity of the Okanogan PUD System, the Project shall not operate its system or equipment in such a manner as to cause a Voltage Unbalance greater than 1% nor a current unbalance greater than 5% at the Connection Point. Any unbalance condition in excess of the specified limits for a duration greater than or equal to one minute is not allowed. Phase unbalance is defined as the percent deviation of one phase from the average of all three phases.

2. Okanogan PUD System Characteristics

All Project equipment connected to the Okanogan PUD System shall be designed to operate within the system conditions defined in this section. These characteristics are typical to the Okanogan PUD System during normal and contingency conditions, but may be exceeded for very short times.

a. Frequency

The frequency of the Okanogan PUD System shall be nominally 60 Hz. Bonneville has installed underfrequency relays to trip under various conditions, as outlined in the appropriate Appendix on Protection.

b. Steady-State Voltage Variations

The transmission and distribution system planning guidelines for Steady State Voltage Variations and Voltage Regulation at the Connection Point are listed in Table 3.

Table 3. System Voltage Variations at the Connection Point

Nominal Voltage (kV)	Absolute Voltage		Voltage Regulation	
	Minimum	Maximum	Normal	Contingency
13.2	95%	105%	5%	7%
115	95%*	103%	5%	5%

* On unregulated 13.2 kV, maximum allowable contingency drop is based on Bonneville operating and planning criteria.

c. Harmonic Voltage Distortion

The maximum harmonic voltage distortion at the Connection Point for each High Voltage and distribution voltage level is defined in Table 4.

Table 4. System Harmonic Voltage Distortion Limits

Nominal Voltage (kV)	Maximum Individual Harmonic Voltage Distortion (%)	Maximum Total Voltage Distortion (%)
13.2	3.0	5.0
115.0	1.5	2.5

The limits in Table 4 represent the maximum harmonic voltage distortion at a given connection voltage for a duration less than or equal to one hour on any single day. The maximum harmonic voltage distortion shall not exceed 150% of the limits for a given

connection voltage for a duration greater than five minutes on any two days during a six month period.

d. Voltage Unbalance

The maximum Voltage Unbalance on the Okanogan PUD System at the Connection Point for a duration greater than or equal to one minute should be less than or equal to 2.0%.

e. Transient Overvoltages

The maximum peak Transient Overvoltage at the Connection Point should be less than or equal to 200% of the nominal system peak voltage.

f. Temporary Overvoltages

The maximum Temporary Overvoltage at the Connection Point shall be less than 180% of the nominal system voltage.

3. Switchgear

a. All Voltage Levels

Circuit breakers, disconnect switches, and all other current carrying equipment connected to Okanogan PUD's transmission and distribution facilities shall be capable of carrying normal and emergency load currents without damage. For Interconnections, the equipment shall not become a limiting factor (bottleneck) in the ability to transfer power on the Okanogan PUD System.

All circuit breakers and other fault-interrupting devices shall be capable of safely interrupting fault currents for any fault that they are specified to interrupt. Application shall be in accordance with ANSI/IEEE C37 Standards. These requirements apply to the generation site, the interconnecting substation, the Connection Point as well as other locations on the Okanogan PUD System. Minimum fault-interrupting requirements are supplied by Okanogan PUD as part of the Connection Study, and are based on the greater of the fault duties at the time of the connection request or those projected in long-range plans.

b. Circuit Breaker Operating Times

Table 5 specifies the operating times typically required of circuit breakers on the Okanogan PUD System. These times also apply to equipment at the generation site and the Connection Point. System stability considerations may require very fast opening and reclosing times. The total automatic recloser time is the summation of the breaker interrupt and close time plus intentionally added delay to allow for de-ionization and subsequent extinction of the fault arc (referred to as the dead timer delay), and the protective relay requirements. The following table shows Okanogan PUD's required interrupting time of the breaker and the dead "timer" delay at system voltages.

Table 5 Circuit Breaker Operating Times

Voltage Class	Rate Interrupting Time (Cycles)
115 kV	5
Below 109 kV	8

c. Other Fault-interrupting Device Operating Times

Depending on the application, Okanogan PUD may allow the use of other fault-interrupting devices such as circuit switchers. Trip times of these devices are generally slower, and current interrupting capabilities are often lower than those of circuit breakers. Often circuit switchers are utilized to isolate generator step-up transformers from the transmission breakers. The dead "timer" delay on circuit switchers is typically 15 seconds and consequently, these devices usually are not reclosed.

4. Excitation System and Power System Stabilizers

The excitation system and power system stabilizers shall comply with WECC and NERC Reliability Standards for maintaining, testing and reporting. Bus voltage control shall be operated in the automatic-terminal-Voltage Regulation mode. For planned operation in manual mode, the Plant Operator shall obtain the approval of the Okanogan PUD Engineering Department in advance. For unplanned, forced operation in manual mode, the Plant Operator shall notify the Engineering Department within 1 hour of switching to manual mode. Operation in the manual mode for extended periods shall only be permitted when approved by the Engineering Department.

All new or replacement voltage regulators are required to have a load compensation circuit. Based on system conditions, it may become necessary to add load compensation to existing systems.

A power system stabilizer (PSS) uses auxiliary stabilizing signals to control the excitation system to improve power system dynamic performance. WECC requires that all individual generating units with a capacity in excess of 20 MVA, or that are part of a generating complex with an aggregate generating capacity in excess of 75 MVA, install a power system stabilizer on the generator excitation system(s).

The latest IEEE Std. 421.4, Guide for the Preparation of Excitation System Specifications, shall be consulted in designing the excitation system. Additional requirements or a change in technical specification may be identified as a result of system studies.

The excitation system is critical to overall system performance. Okanogan PUD reserves the right to specify these settings initially or revise the settings at any time during the life of the generator as warranted by system conditions.

Projects shall have maintenance and testing programs for excitation systems in compliance with applicable NERC Reliability Standards.

5. Governor Speed and Frequency Control

A speed governor system is required on all generators. The governor regulates the output of the generator as a function of system frequency and desired MW output. This function is called the governor's droop characteristic and shall be coordinated with the governors of other generators located within the same control area, to assure proper system response to frequency variations. All speed governor systems shall respond to system frequency changes to help maintain the stability of the power system. The speed governor system shall have a droop characteristic that is typically set to five percent. Droop equals change in frequency or speed, in per unit of nominal, divided by change in generator load, in per unit of full load. An example equation is: $0.05 = (0.1/60)/0.0333$; where if a generator has a 5% droop setting, a system frequency change of 0.1 Hz, will cause the generator load to change by 3.33% (ignoring deadbands and other non-linearity's).

The Project shall have maintenance and testing programs for the Project governor control system in compliance with applicable NERC Reliability Standards.

6. Voltage Regulation and Reactive Power Requirements

a. Okanogan PUD Transmission & Distribution System Voltages

Okanogan PUD operates its transmission and distribution system within the voltage guidelines defined below. Projects shall operate within the full voltage range at the Connection Point without restricting the operational range of the Okanogan PUD System.

Table 6. System Voltage Guidelines

Nominal Voltage (kV)	Absolute Voltage		Voltage Regulation	
	Minimum	Maximum	Normal	Contingency
13.2	95%	105%	5%	7%
115	95%*	103%	5%	5%

* On unregulated 13.2 kV, maximum allowable contingency drop is based on Bonneville operating and planning criteria.

b. Voltage Schedules and Operation of the Project

Major generators (as determined by Okanogan PUD) are provided voltage schedules by Douglas PUD and/or Bonneville. Voltage schedules are necessary for efficient and reliable electric power operations for adequate service to loads. The voltage schedules establish operating requirements for generators and may be set for seasons, holidays, days of the week, and time of day. These schedules may be changed at any time by the Bonneville system operator to meet transmission and distribution system requirements. When requested by Bonneville/Douglas PUD or the Engineering Department, Project Operators shall provide the date, duration and reason for a generator not maintaining the established voltage schedule.

Generator step-up (GSU) transformers (unit transformers) shall have taps that cover the entire range of possible system voltages given in the previous section, with less than or equal to 2.5% difference between adjacent taps. The GSU tap shall be set to allow the generator to produce or absorb reactive power between 0.95 leading and 0.90 lagging power factor to meet the voltage schedule. At the same time, the plant electrical system shall be designed so that all modes of unit operation are not restricted by system operation within the voltage range given in the previous section. In the Project design phase, the Project Sponsor shall demonstrate to Okanogan PUD that the Project meets these requirements.

Dynamic sources of reactive power, such as synchronous generators, are necessary to operate a reliable power system. Therefore, synchronous generators are required to participate in Voltage Regulation by meeting voltage schedules. Operating requirements for each Project are determined by facility studies and/or operating experience with similar Projects. Operating requirements may be refined by Okanogan PUD or Bonneville based on actual Project operating experience or future system changes.

1. Synchronous Generators And Projects With Solid State Inverters

Synchronous generators and Projects with solid-state inverters are required to produce or absorb reactive power up to the temporary thermal capability of the generator during disturbances.

The voltage regulator is set to maintain constant voltage rather than constant power factor. The regulator set point is coordinated with voltage schedules in the area. The Project generators are not required to operate at more than 105% or less than 95% of the nominal voltage rating of the generators under steady state conditions. However, seasonal adjustment of the transformer tap settings may be required when voltage schedules are changed by the Engineering Department, or Douglas PUD/Bonneville. It is the Project Sponsor or Project Operator's responsibility to ensure that the voltage regulator is initially set up correctly to allow the full range of adjustability. If the midpoint of the range of adjustability (or operating range "window") is not set correctly the ability of the regulator to be adjusted may be significantly reduced in either the raise or lower position.

2. Induction Generators

Projects using induction generators (without solid-state inverters) are usually not required to participate in Voltage Regulation; however they shall not adversely affect voltage schedules. The Facility Study determines the reactive power capability necessary to insure that these voltage schedules are maintained.

c. Reactive Power and Voltage Regulator Requirements

1. Synchronous Generators And Projects With Solid State Inverters

Each Project of this type shall also have a voltage regulator capable of maintaining stable voltage at the generator terminal, within 0.5 percent of any set point. The operating range of the regulator shall be at least plus or minus five percent of the rated voltage of the generator.

The generator continuous reactive capability between 0.95 leading and 0.90 lagging power factor shall not be restricted by any main or auxiliary equipment, e.g. main or auxiliary transformer settings, hydrogen cooling system, stator water cooling system, equipment voltage or current ratings, control, protection, and so on. The GSU shall be chosen so as not to limit the real or reactive power output of the generator. IEEE Standard C57.116, IEEE Guide for Transformers Directly Connected to Generators, shall be consulted when specifying the GSU turns ratio, impedance, etc.

Projects shall have a program to verify the gross and net reactive power capability in compliance with applicable NERC Reliability Standards.

2. Induction Generators

Projects using induction generators (without solid-state inverters) shall provide at a minimum, sufficient reactive power capability or the "equivalent" to deliver the Project output at unity power factor at the Connection Point. "Equivalent" reactive power includes adding shunt capacitors at locations other than at the Connection Point or the Generation Site or acquiring sufficient reactive power from Okanogan PUD or another utility. Okanogan PUD determines the acceptable locations for "equivalent" reactive using the results of the Facility Study.

Power factor correction capacitors added to the Project to meet the unity power factor requirement shall be switchable while energized. Depending on the size of the Project and the location, these capacitors shall be switched to anticipate Voltage Regulation. The control methods and set points for switching these capacitors shall be coordinated by Okanogan PUD with voltage schedules in the area.

7. Voltage and Frequency Operation During Disturbances

Power system disturbances initiated by faults, forced equipment outages, etc., expose connected generators to oscillations in voltage and frequency. It is important that generators remain in service while the oscillations are damped and the system returns to a stable operating point. Therefore each generator shall be capable of continuous operation at 0.95 to 1.05 pu voltage and 59.5 to 60.5 Hz and limited time operation for larger deviations. Nearly all generators have inherent capability for off-nominal operation. Over/under voltage and over/under frequency relays are normally installed to protect the generators from extended off-nominal operation. To insure that the Project generator is not tripped prematurely, the required time delays for setting these relays are presented in the appropriate Appendix on Protection.

To avoid large-scale blackouts that can result from excessive generation loss during a disturbance, underfrequency load shedding has been implemented throughout the Northwest. When system frequency declines, loads are automatically interrupted in discrete steps. Load shedding attempts to stabilize the system by balancing the generation that is still running and load. It is imperative that generators remain connected to the system during frequency declines, both to limit the amount of load shedding required and to help the system avoid a complete collapse. This need, as well as the restricted ability of some generators to withstand off-nominal frequency operation, has been taken into account in the relay-setting delays provided in this document. See the appropriate Appendix on Protection.

To avoid voltage collapse within the Douglas System and/or Bonneville System, undervoltage load shedding has been implemented. The Project's undervoltage relaying shall coordinate with Douglas PUD's or Bonneville's undervoltage load shedding program. See the appropriate Appendix on Protection.

For those generators connected to Okanogan PUD through a tapped line, a 'local island' is created when the breakers at the ends of the transmission line open. This leaves the generator and any other loads that also are tapped off this line isolated from the power system. Delayed fault clearing, overvoltages, ferroresonance, extended undervoltages, etc., can result from this 'local island' condition and are therefore not allowed to persist on Okanogan PUD facilities. For protection, special relaying and settings may be used to disconnect the generator(s) in the 'local island' (See the appropriate Appendix on Protection.)

E. Protection Requirements & Guidelines

Refer to appropriate Appendices for different connections to the Okanogan PUD System.

Appendix C-1: Protection Requirements and Guidelines - Non-Utility Generator Connection to Okanogan PUD:

This shall cover Project Sponsor generator(s) more than 5 MW or 50% of light load, whichever is the lesser value, connected to Okanogan PUD's 115 kV facilities. Appendix C-1 shall cover the protection requirements and shall provide guidelines accommodating the generating facilities to be connected to the Okanogan PUD System. This document identifies protective relay scheme modifications on the Okanogan PUD System as well as recommendations for the relay scheme to be installed at the Project Sponsor's generating facility.

Appendix C-2: Protection Requirements and Guidelines - Interconnection:

This document shall cover the protection requirements for bulk power Interconnection between Okanogan, Douglas PUD, Bonneville, and Balancing Authority areas other than Douglas PUD or Bonneville.

Appendix C-3: Protection Requirements and Guidelines – Small Generator Connection:

This document shall cover the protection requirements for Generation – Distribution Connection Projects.

F. SCADA, Metering and Telecommunication Requirements

This section states the minimum requirements for SCADA, metering and telecommunication associated with Projects connected to the Okanogan PUD System. All Projects that are connected to the Okanogan PUD System shall require metering equipment with revenue-metering-accuracy (i.e. metering enclosure with meter, associated equipment, instrument transformers, and certain interface enclosures with associated isolation devices) and the equipment shall belong to Okanogan PUD. Most SCADA analog values require revenue-metering accuracy.

At Project's expense, all of the following equipment for SCADA, metering and telecommunications shall be owned, operated and maintained by Okanogan PUD.

Adequate space in an environmentally suitable and secure room with A/C & D/C supply, lights and cable trays shall be made available for sensitive equipment. Battery power back-up sufficient for 8-hour continuous operation of all devices is required. The following 19"-rack spaces (60" height) are required. For working clearance, approximately 3.5-foot clearance for front, and for back, of the 19"-racks is required.

- 0.5 rack space for protection relays for each line/feeder bay & breaker
- 1 rack space for all SCADA – RTU and telecommunications equipment
- 2 vacant rack spaces for future growth (located at both ends)

Where applicable, the Project Sponsor shall provide full access to the equipment by Okanogan PUD operating staff to maintain or to calibrate equipment owned by Okanogan PUD. If Project Sponsor installs locks, Okanogan PUD personnel shall be able to use existing District keys issued to them to gain access.

1. Supervisory Control and Data Acquisition (SCADA)

The SCADA - RTU shall be installed at the Project facility for remote energy management of Project's devices by Okanogan PUD's Engineering Department and for Douglas PUD system operators, if appropriate. It shall be for the control, indication, monitoring, archiving and energy accounting of all breakers and devices at the Connection Point necessary to operate the Okanogan PUD System, Douglas PUD and/or Bonneville System in a manner consistent with Prudent Electric Utility Practices.

The RTU compatible with Okanogan PUD's SCADA master, shall be procured, installed, tested and maintained by Okanogan PUD at Project expense. Okanogan PUD will work with Douglas PUD as necessary to interface the RTU with the Douglas PUD SCADA. RTU size and point count to include alarms, analogs, accumulators, control-and-indication points, and any additional peripheral equipment shall be determined on a case-by-case basis.

2. Metering

At Project's expense, all metering design and construction drawings must be stamped by a Washington State licensed electrical engineer prior to submittal to Okanogan PUD for approval. The metering package shall be designed to conform to Okanogan PUD metering standards.

At Project's expense, Okanogan PUD's metering equipment shall be installed and maintained on the low voltage side of the Connection Point. If installed at the low voltage side of the Connection Point then, power transformer and/or line losses shall need to be considered. If metering is installed at the 115 kV level, separate Station Service metering

may be required to maintain accuracy. Okanogan PUD shall determine when separate metering is necessary.

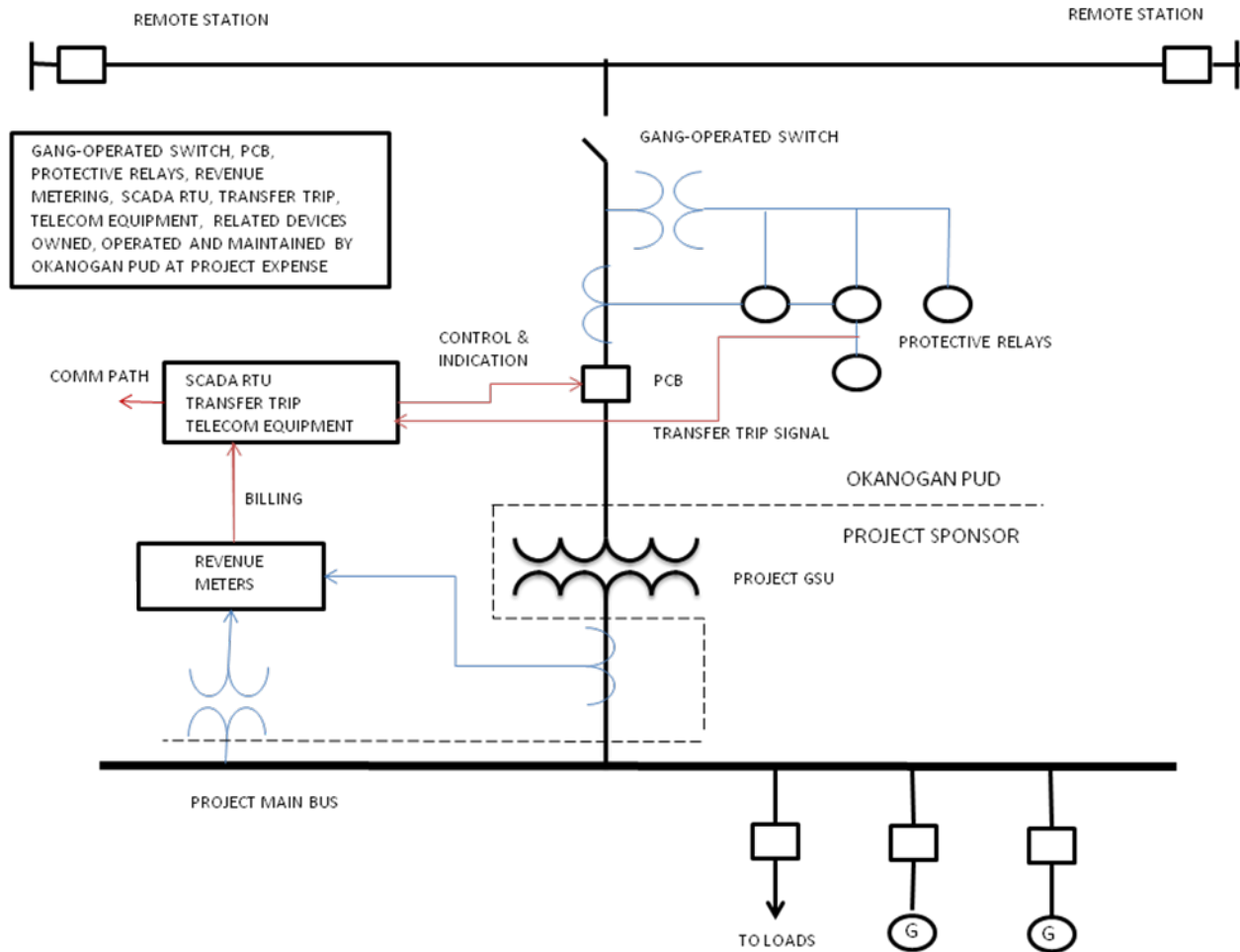

Figure 1. Equipment Calibration & Maintenance at Connection Point (see accompanying Appendix E on Ownership)

a. Metering Equipment Requirements

A bi-directional solid state meter shall be used to measure the real and reactive power interchange between the Okanogan PUD System and the Project. Three-element, three-phase, four-wire meters shall be utilized on wye connected power systems. Two-element, three-phase, three-wire meters shall be utilized on delta connected power systems only when Okanogan PUD determines three-element metering is impractical for a given application.

For metering equipment located in the Project substation, the installation of metering test switches is required. The metering devices shall be consistent (approved meter type and communication media) with Okanogan PUD’s remote metering and data acquisition system.

b. Meter Accuracy

Meters shall be calibrated in accordance to Okanogan PUD standards.

c. Instrument Transformers

Voltage and current transformers shall be 0.3% metering accuracy class for both magnitude and phase angle over the burden range of the installed metering circuit. Instrument transformer correction factors may be applied to the meter to adjust the meter for inaccuracies associated with the secondary burdens in the current transformer and voltage transformer circuits. In bi-directional situations where there are significant differences in the magnitude of capacity delivered to the Okanogan PUD System compared to the load supplied by it, good engineering practices shall be in place to accurately meter power flow in both directions. All instrument transformers shall comply with ANSI/IEEE Standard C57.13.

d. Loss Compensation

If the metering is not located at the Connection Point, then power transformer and/or line loss compensation shall need to be considered. Okanogan PUD approved power transformer and/or line loss compensation values shall be applied to the meter to properly compensate for the losses in the power transformer and/or line.

The Project Sponsor is required to calculate the loss compensation and clearly document the values. The calculations are subject to Okanogan PUD's review and approval before a permanent connection of the Project is permitted.

e. Project's Access to Metering Data

If access to the meter is required, proper security measures shall be taken to ensure the integrity of the meter is not compromised. If data pulses are required from the revenue meter, then the appropriate isolation equipment shall be installed to properly protect the revenue meter. The data pulses supplied shall conform to Okanogan PUD standards. If additional information or reports are requested, they shall be coordinated with Okanogan PUD.

The Project Sponsor is required to maintain metering information consisting of meter-relay one-line diagrams, scale factors, CT & PT ratios, transformer test data, meter calibration and any meter test reports in a 3-ring binder at the site. All information in the binder shall be accessible and the contents are subject to Okanogan PUD's review and approval.

f. Station Service Power

Metering requirements for Station Service power, if any, shall be determined on a case-by-case basis. The Project Sponsor shall apply for retail electric service for Station Service power separately from the Project connection service request. The Project Sponsor shall submit a completed Application for Commercial Service to Okanogan PUD's New Services Department at the time it executes a Reimbursement Agreement.

g. Calibration of Metering Facilities

Metering facilities shall be tested and calibrated by Okanogan PUD every five years. The Project Operator may request more frequent test intervals; however, the District shall perform such additional calibration testing at Project Operator expense, unless the tests demonstrate that metered amounts are outside of an acceptable range of accuracy. Under such circumstances, Okanogan PUD shall bear the cost of the calibration testing and the Project Operator and the District shall negotiate a mutually agreeable settlement to resolve the discrepancy. All interested parties or their representatives may witness the calibration tests. Calibration records shall be made available to all interested parties. The accuracy of the standard utilized for calibration purposes shall be traceable to the National Institute of Standards and Technology (NIST).

h. Totalized Metering & Special Meters

When totalized metering is requested, it may be installed at Project's expense. It shall be Okanogan PUD's option to provide totalized meter data either by hard-wired method or by summing various meters through use of a PC and billing software. Special metering to meet the Project Sponsor's need may be installed if primary metering accuracy is not compromised nor instrument transformer burdens exceeded.

3. Voice Communication – Phone Line and /or Radio Coverage

Voice communication is required between Okanogan PUD's Engineering Department and the Project Operator and/or Okanogan PUD's operating crews.

A typical phone line at the Project is sufficient to supply this communication path. In the event that the Project is supplying additional services (AGC, load following, reserves, system restoration, etc.) or if the Project is in excess of a specified generation capacity, back up communication with the Project is necessary. Independent voice communications for coordination of system protection, control, and communications maintenance activities between Okanogan PUD and the Project is required in addition to the communications stated above.

If Okanogan PUD crews are required to maintain lines or station equipment at or near the Project facility, two-way radio coverage is needed. At Project's expense, Okanogan PUD may apply for modification of FCC licenses, relocate existing radio transmitters, install radio towers, communication buildings, microwave transmitters and/or acquire additional radio transmitters (and channel banks) to provide 95% probability of radio coverage

- along the route to the site, and
- at the Project facility itself.

The radio channels and the functional capabilities of the radio transmitter(s) shall be compatible with Okanogan PUD's:

- radios now installed in operating crew vehicles
- transmitter(s) central controller

- System Engineering Departments' consoles/console interface, and
- radio test equipment, jigs and "flash memory" programs

4. Data Communications

All generating and transmission/distribution facilities shall have in place, a means of transmitting monitoring, accounting, and control data where appropriate to the Okanogan PUD Engineering Department or designated communications "hub". In general, communications system availability for data on Okanogan PUD's main communication paths achieves a system availability of 99.995% or better. At Project expense, additions and maintenance to Okanogan PUD's communications shall be comparable to the aforementioned system availability figures.

If repeated outages occur, the Project Operator may be required to log the outages electronically and submit them to Okanogan PUD for evaluation. If the communication system fails to meet availability of 99.995% or better, the Project Operator is required to add backup communication equipment and communication paths at its expense.

a. SCADA

SCADA requirements consist of microwave channels, or fiber-optics from the site to the Engineering Department, and, if required, the Douglas PUD and/or Bonneville system operations center. These are dedicated channels. Factors involved in selecting a type of circuitry are availability, proximity to the site, and cost. Fiber is preferred. Okanogan PUD shall determine whether alternative communication channels may be implemented on a case-by-case basis.

b. AGC

Data for AGC calculations and control is transferred to the Douglas PUD System Operations center, if required.

c. Energy Accounting

Energy accounting data may be transmitted from the site to the Engineering Department and the Douglas PUD System Operations center by an RTU and/or telemetering, and/or dial-up phone lines through any one of the above mentioned data communication media.

5. Separate Telecommunications for Revenue-accuracy Metering

At Project expense, a compatible and reliable communication channel maybe required for remote interrogation of the meter, collect, merge, and store metering data with Okanogan PUD and, if required, Douglas PUD's remote metering and data acquisition system.

6. Telecommunications for Protection & Transfer Trip

Telecommunication channels shall be used for transfer trip if performance of the channel and the equipment meets the "Protection Requirements & Guidelines" of the connection.

Communications for Protection shall function at the full performance level before, during, and after any power system fault condition (Service Performance Objective Class A per IEEE Standard 487).

a. Speed of Operation

Throughput operating times of the telecommunications system shall not add unnecessary delay to the clearing or operating times of protection or remedial action schemes. Maximum permissible clearing times for faults are specified in "Protection Requirements & Guidelines" section. The throughput operating times of the telecommunications system is only a portion of that total clearing time.

b. Equipment Compatibility

In order to provide maintainability and operability between the Project, the Okanogan PUD System, the Douglas PUD System, and the Bonneville System, transfer trip units shall be acquired, installed, tested, owned, operated and maintained by Okanogan PUD and/or Douglas PUD/Bonneville at the expense of the Project. "Tone" equipment shall be of the same manufacturer and type. The need for or implementation of peripheral capabilities such as signal counters, test switches, etc., are not required to be identical to those used at Okanogan PUD, Douglas PUD, or Bonneville facilities but they shall be supplied by the Project Sponsor. Okanogan PUD shall consider the use of alternative equipment and/or technologies as proposed by the Project Sponsor as long as the equipment is suitable for the purposes of the application required.

REFERENCES

ANSI / IEEE: ANSI / IEEE Std C37 IEEE Standards for Circuit Breakers, Switchgears, Substations, and Fuses Standards Collection
 ANSI / IEEE Std 80-1986 or latest version, IEEE Guide for Safety in AC Substation Grounding
 ANSI / IEEE Std 100-1992 or latest version, The New IEEE Standard Dictionary of Electrical and Electronic Terms
 ANSI / IEEE C 57.13 IEEE Standards on Instrument Transformers
 ANSI / IEEE 367 IEEE Recommended Practice for Determining the Electric Power Station Ground Potential Rise and Induced Voltage from a Power Fault
 ANSI / IEEE Std 446 Emergency & Standby Power for Industrial & Commercial Applications
 ANSI / IEEE 665 Guide for Generating Station Grounding

Institute of Electrical & Electronics Engineers, Inc.

(IEEE): IEEE C37.95 Guide for Utility-Consumer Interconnections
 IEEE C37.102 Guide for AC Generator Protection
 IEEE Std C57.116 IEEE Guide for Transformers Directly Connected to Generators
 IEEE 81 Part 1 Guide for Measuring Earth Resistivity, Ground Impedance, and Earth Potentials
 IEEE 81 Part 2 Measurement of Impedance and Safety Characteristics of Large, Extended or Interconnected Grounding Systems.
 IEEE Std 421.4 Guide for Preparation of Excitation System Specifications
 IEEE 487 Protection of Wire-Line Communication Serving Electric Power Stations
 IEEE 837 Standard for Qualifying Permanent Connections Used in Substation Grounding

National Electrical Safety Code (NESC):**National Electrical Code**

(NEC): Article 705, 1999 or latest version

National Institute of Standards and Technology (NIST):**North American Electric Reliability Council**

(NERC): Reliability Standards

Occupational Safety and Health Administration

(OSHA): Standard 29 CFR 1910.269 or later

Okanogan PUD

Okanogan PUD: [?]

Uniform Building Code (UBC):**Washington State Administrative Code**

(WAC): WAC Rules

Washington Industrial Safety and Health Administration

(WISHA): WISHA Standards

Western Electricity Coordinating Council

(WECC): Progress Report Policies and Procedures
 Reliability Criteria for Transmission System Planning
 Policy Statement on Power System Stabilizers
 New Generation Connection Policy
 Coordinated Off-Nominal Frequency Load Shedding and Restoration Program
 Voltage Stability Criteria
 Procedures for Regional Planning Project Review & Rating Transmission Facilities
 Testing Guidelines for Synchronous Unit Dynamic Testing & Model Validation

Version	Date	Action	Change/Tracking
4.0	12/28/2011	Created	
4.1	12/19/2017	Minor changes to definitions and sections A5, B1. Added Revision Table.	TD
4.2	12/19/2018	Reviewed	AA
4.3	12/20/2019	Review Corrected Versions	AA
4.4	12/29/2020	No Changes	AA
4.5	12/14/2021	No Changes	DS/AA
4.6	12/19/2022	No Changes	DS/AA